



## AQUAPURA MONOBLOC

120i







Esteemed Client,

We would like to thank you for your choice when you acquired an equipment for sanitary water heating.

**AQUAPURA MONOBLOC** aero-thermal system will surely meet all your expectations and provide many years of comfort with maximum power saving.

Our organization dedicates much time, energy and economic resources in order to develop innovations that will promote power saving in our products.

Your choice has demonstrated your good sense and concern with power consumption, a matter that affects the environment.

We have taken on a permanent commitment to conceive innovative and efficient products so that this rational use of energy can actively contribute to the preservation of the environment and natural resources of the planet.

Keep this manual whose objective is to inform, alert and advise about the use and maintenance of this equipment.

This instruction manual can be found on the website:"  
<https://energie.pt/en/produto/heat-pumps/domestic-use-heat-pump/domestic-hot-water-dhw-domestic-use-heat-pumps/aquapura-monobloc-120/>"

Our services are always at your disposal. Feel free to call upon us!



## Index

<b>1. INTRO</b>	<b>6</b>
1.1. Symbols	6
1.2. Safety Information	6
1.3. Information	7
<b>2. SPECIFICATIONS</b>	<b>9</b>
2.1. Components	9
2.2. Running Principle	10
2.3. Technical Data	11
<b>3. TRANSPORT</b>	<b>12</b>
<b>4. INSTALLATION</b>	<b>12</b>
4.1. Safety and Control Devices	12
4.1.1. High/Low Pressure Switch	12
4.1.2. Safety Thermostat	12
4.1.3. Temperature Probe	12
4.1.4. Expansion Vessel*	12
4.1.5. Safety Group*	13
4.1.6. Pressure Reducing Valve*	13
4.2. Positioning	14
4.3. Air Inlet/Outlet Installation	15
4.3.1. Installation without Ducts	15
4.3.2. Installation with Ducts	15
4.4. Hydraulic Installation	18
4.5. Thermodynamic Group Access	19
4.6. Condensates	20
4.7. Electrical Connections	20
4.8. Electrical Diagram	21
<b>5. CONTROL and PROGRAMMING</b>	<b>22</b>
5.1. Control Panel	22
5.2. Keys (Functions)	22
5.3. Display	22
5.4. User Interface	23
5.5. User interface	24
5.5.1 - ON/OFF equipment	24
5.5.2 – Lock/unlock the keypad	24
5.5.3 – Information on the display during working time	24
5.5.4 – Information on the display during working time	24
5.5.5 – Changing working modes	24
5.5.5.1 – ECO mode	24
5.5.5.2 – AUT mode	25
5.5.5.3 – OBS mode	25
5.5.6 – Setpoints	25
5.5.6.1 – Change ECO mode setpoint (SP1)	25
5.5.6.2 – Change AUT mode setpoint (SP2)	26
5.5.6.3 – Change OBS mode setpoint (SP3)	26
5.6. Anti-Legionella Function	26

5.7.	Desfrost function .....	26
5.8.	Photovoltaic function .....	26
5.8.1	– Activate the photovoltaic function.....	26
5.9.	Parameter configuration .....	27
5.9.1	– Access controller parameters.....	27
5.9.1	– Controller parameters .....	27
<b>6.</b>	<b>ERRORS.....</b>	<b>30</b>
<b>7.</b>	<b>PROBE CHART .....</b>	<b>31</b>
<b>8.</b>	<b>TROUBLESHOUTING .....</b>	<b>32</b>
<b>9.</b>	<b>SYSTEM MAINTENANCE .....</b>	<b>34</b>
9.1.	General Inspection .....	34
9.2.	Empty the Water Storage .....	34
9.3.	Filter of Reduction Valve .....	34
9.4.	Condensate circuit.....	34
9.5.	Cleaning Air Circuit.....	34
9.6.	Safety Thermostat .....	35

## 1. INTRO

### 1.1. Symbols

	<p>Every process that the supplier believes to be conducive to harmful danger and/or material damage will be signalled with a danger sign. To better characterize the danger, the symbol will be followed by one of these words:</p> <ul style="list-style-type: none"> <li>• <b>DANGER:</b> when there is the possibility of harm to the operator and/or people in the vicinity of the equipment</li> <li>• <b>WARNING:</b> when there is the possibility of material damage to the equipment and/or attached materials.</li> </ul>
	<p>All the information that the supplier believes to be an asset for better performance and preservation of the equipment, will be signalled together with the information sign.</p>

### 1.2. Safety Information

 <b>WARNING/DANGER</b>	
<ul style="list-style-type: none"> <li>• The electrical installation of the equipment must comply with the national regulations for electrical installations in effect.</li> <li>• The equipment can only work if the water heater is filled with water and properly purged;</li> <li>• The electrical supply is 230VAC/50Hz;</li> <li>• The equipment must be connected to an electrical outlet with earth contact;</li> <li>• If the power supply cable is damaged, it must be replaced by the manufacturer, by its customer service, or by staff with similar training in order to avoid any danger.</li> <li>• Children must not play with the device.</li> <li>• Cleaning and maintenance must not be carried out by children without supervision.</li> <li>• • According to standard EN60335-2-40: This device can be utilized by children of 8 years old or more and by people with limited physical, sensorial or mental capabilities or with lack of experience and knowledge if they are being watched or have receive instructions regarding the use of this device in a safe manner and if they understood the risks involved.</li> <li>• • According to standard EN60335-2-21: This device can be utilized by children of 3 years old or more and by people with limited physical, sensorial or mental capabilities or with lack of experience and knowledge if they are being watched or have receive instructions regarding the use of this device in a safe manner and if they understood the risks involved. The children of ages between 3 and 8 can only operate the tap connected to the device</li> <li>• • According to standard EN6335-2-40 + IEC60335-2-21: This device can be utilized by children and people with limited physical, sensorial or mental capabilities or with lack of experience and knowledge if they are being watched or have receive instructions regarding the use of this device in a safe manner and if they understood the risks involved.</li> <li>• The operating principle of this equipment is directly linked to high temperatures and pressures, so all processes that involve contact with the equipment must be prepared with care to avoid risks of burns and material projection.</li> <li>• The heating of other fluids than drinking water is not allowed.</li> </ul>	

### 1.3. Information



#### INFORMATION

##### Installation

- The installation of the equipment must be carried out by staff with suitable training and qualified for this purpose.
- The device **must not be** installed:
  - outdoors;
  - in places with corrosive environment;
  - in places with a risk of temperatures below 5°C;
  - in places that present a risk of impact, shock or explosion.
- The equipment must be installed in a dry place, protected from the weather;
- Keeping the equipment packed until the place and time of installation.
- Ensure that all hydraulic connections are properly watertight before powering the equipment electrically.
- The discharge pipe connected to the pressure limiting device must be installed in a non-freezing environment and continuously directed downwards.
- The discharge tube of the pressure limiting device must be kept open to the atmosphere.

##### Maintenance

- The user is responsible for the safety and environmental compatibility of the installation and/or maintenance.
- Maintenance/repair should only be carried out by a brand assistance service, with the exception of general and continuous cleaning operations, which can/must be carried out by the user himself. Repairs carried out incorrectly can create risks for the user and cause the product to malfunction.
- The supplier recommends that at least an annual inspection of the equipment be carried out by a qualified technician.
- Always switch off the electrical supply to the device before carrying out any maintenance work.
- Cleaning and maintenance must not be done by children without supervision.
- Only use original replacement parts.
- The safety valve must be operated regularly to remove impurities and check that it is not blocked.
- To drain the water from the water heater, close the supply valve and open the drain valve.



**\* Pressure Reducing Valves**

- Pressures admitted upstream of the pressure reducing valve:
  - Maximum pressure allowed 1.2 Mpa;
  - Minimum pressure allowed 0.1 MPa;
- Pressure downstream of the pressure reducing valve:
  - Factory set to 0.3 MPa;

**\* Safety Group**

The safety group allows the system to be protected in the event of anomalies in the supply of cold water, hot water return, emptying of the water heater and high pressures. The valve is calibrated to operate at 0.7 MPa.

**Refrigerant**

- Handle and recycle refrigerant gas, if necessary, in compliance with environmental laws. It cannot be released into the environment!
- The refrigerant gas is R134a, free of CFCs, non-flammable and without harmful effects on the ozone layer.
- Before carrying out any intervention on the components of the refrigerant circuit, evacuate/recover the refrigerant gas in order to carry out the operations safely.
- In maintenance, it must be taken into account that fluorinated greenhouse gas HFC-134a is used, covered by the Kyoto protocol GWP=1300.
- All gas handling must be carried out by a qualified technician.

**In operation**

- Water pressure:
  - Minimum 0,1 MPa;
  - Maximum 0,7 MPa;
- Water temperature:
  - Minimum 5 °C;
  - Maximum 65 °C;

**Information to give to the customer**

- The installer must inform the customer about the operation of the appliance, instruct him on its handling, and the customer's rights and duties.
- Communicate to the customer the fact that the alteration or maintenance of the device must only be carried out by specialized and accredited personnel.

(\*)

Components not supplied with the equipment.  
We strongly recommend its installation.



To request additional information, contact us via the email address [energie@energie.pt](mailto:energie@energie.pt) or via our website [www.energie.pt](http://www.energie.pt).

## 2. SPECIFICATIONS

### 2.1. Components

The AquaPura Monobloc 120L package contains:

- Hot water storage heater, in stainless steel:

#### Dimensions:

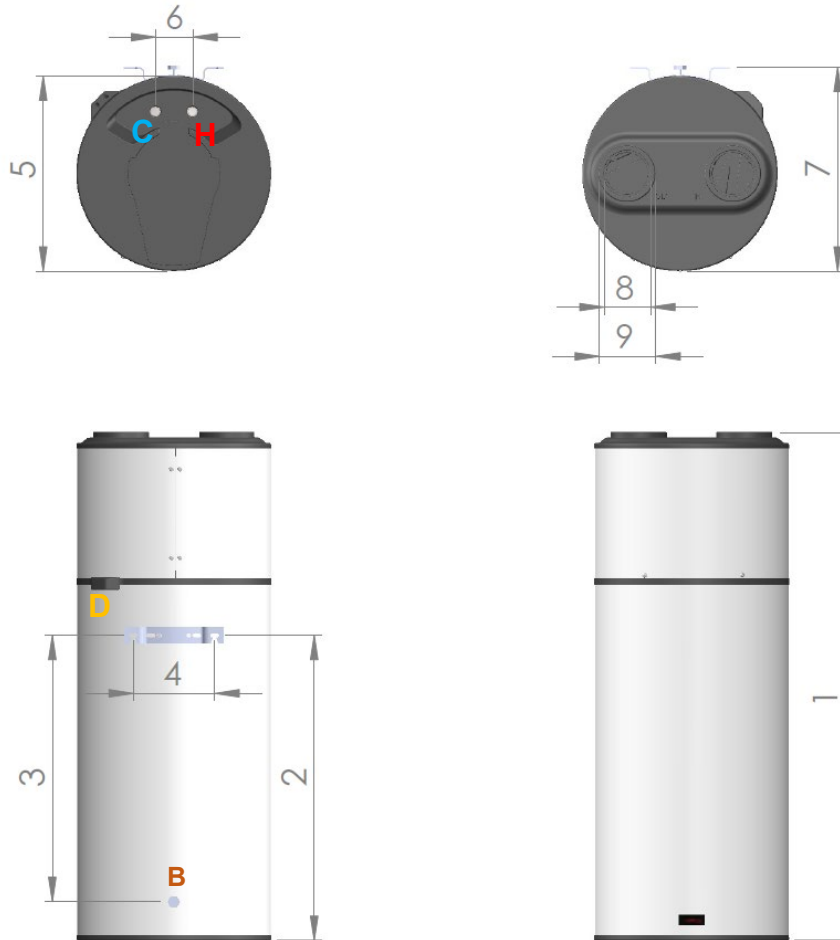

- H** – Hot Water
- C** – Cold Water
- D** – Drain
- B** – Backstop

	120
<b>1</b>	1350 mm
<b>2</b>	826 mm
<b>3</b>	720 mm
<b>4</b>	220 mm
<b>5</b>	Ø530 mm
<b>6</b>	100 mm
<b>7</b>	550 mm
<b>8</b>	Ø125 mm
<b>9</b>	Ø150 mm
<b>Q</b>	3/4" M
<b>F</b>	3/4" M

- A cooling system, at the top, responsible for transferring heat from ambient air to sanitary water;

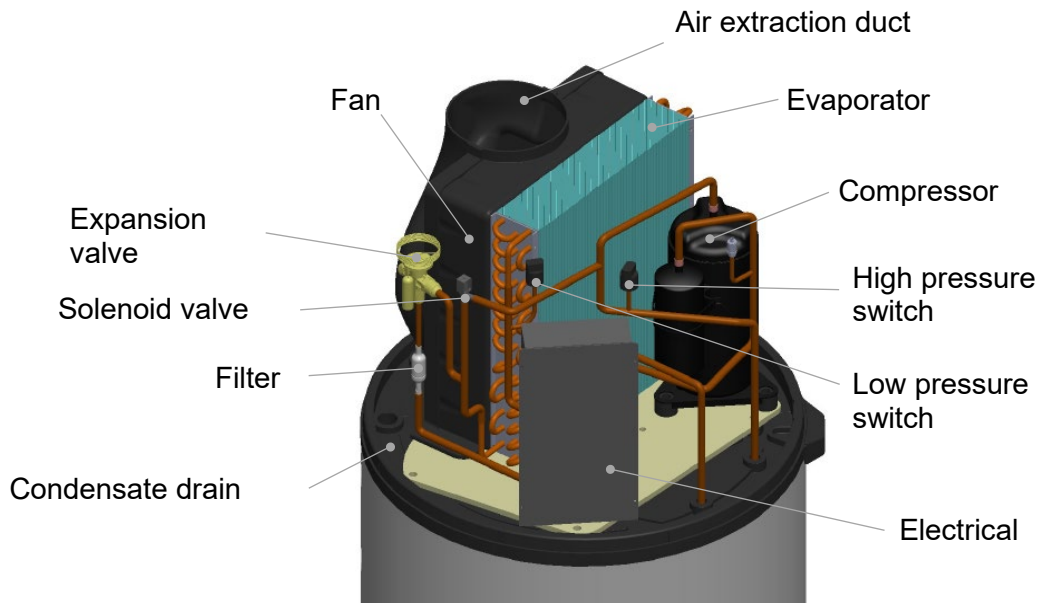

## 2.2. Running Principle

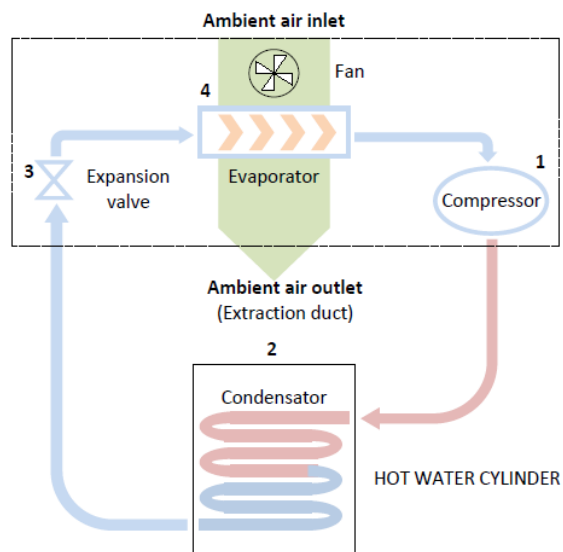

1. The cooling fluid (R134a) is compressed in the high efficient compressor, raising its pressure and temperature;
2. In the condenser (not in direct contact with the water), the heat energy in the cooling fluid is transmitted to the water in the water storage heater;
3. The condensate fluid (high pressure) runs from the expansion valve which is responsible for easing the its pressure;
4. The fluid absorbs heat energy from the environment by flowing through the evaporator with the help of a fan;



The R134a is a HFC fluid, thus not harmful to the ozone layer. It has great chemical and thermal stability, low toxicity, non-inflammable, and is compatible with most materials.

### 2.3. Technical Data

	Unit	120i
Type of Equipment	-	Air/Water Heat Pump for DHW
Nominal Capacity	L	114
Empty Weight	Kg	43
Dimensions (ø/height)	-	Ø530/1350
Storage Water Heater Material	-	Stainless Steel
Insulation	-	High-density polyurethane 50mm
Max Running Temperature	°C	80
Max Working Pressure	bar	7
Test Pressure	bar	10
Heat Loss	kWh/24h	0,95
Protection Index	-	IPX1
Power Supply	-	220-240 Vac / monophasic / 50 Hz
Absorbed Power (med / max)	W	250/350
Absorbed Power Electrical Support	W	1500
Thermal Power Supplied BC	W	1550
Ventilator Power	W	65
Max Running Current	A	1,6 + 6,8 (with backup electrical heater)
Max DHW Temperature (BC)	°C	60
Max DHW Temperature (Backup)	°C	70
Refrigerant	-/kg	R 134a / 0,7
Load Profile	-	M
COP <sup>1)</sup>	-	2,8
Heating Time <sup>1)</sup>	(hh:mm)	05:30
Amount of Useful Water 40°C <sup>1)</sup>	L	139
Energy Efficiency Class <sup>1)</sup>	-	A+
Energy Efficiency <sup>1)</sup>	%	117
Annual Electricity Consumption <sup>1)</sup>	kWh/year	438
Ambient Temperature Limits	°C	-5/40
Sound Power Level Indoor <sup>2)</sup>	dB(A)	49
Sound Pressure at 2m	dB(A)	34
Air Flow	m <sup>3</sup> /h	195
Static Pressure Fan	Pa	60
Max Ducts Length	m	20

1) A14/W10-54, according EN16147 and Delegated Regulation No. 812/2013

2) According with EN12102

### 3. TRANSPORT

	<p>The equipment must be carried in an upright position.                  The equipment must be raised and lowered with extreme care, to avoid impact that could damage the material.                  Make sure the belts and/or transportation straps do not damage the material.                  Always use suitable means to transport the material (pallet lift, forklift, etc.)</p>
-----------------------------------------------------------------------------------	--------------------------------------------------------------------------------------------------------------------------------------------------------------------------------------------------------------------------------------------------------------------------------------------------------------------------------------------------------------------------------------------------------





**Correct transport position:**

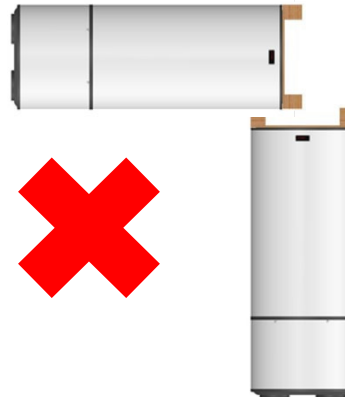

**Wrong positions for transport:**



The equipment must be transported in its original package to the place of installation.  
 The packages contain the following information symbols:

	Fragile, handle with extreme caution		Keep the package dry
	Make sure the arrows are always up		Do not stack packages

### 4. INSTALLATION

#### 4.1. Safety and Control Devices

##### 4.1.1. High/Low Pressure Switch

In case of running outside the range of pressures recommended and defined by the supplier, the equipment will switch off and indicate error in the electronic panel.

##### 4.1.2. Safety Thermostat

The safety thermostat is set by the supplier to ensure that the water temperature in the storage water heater does not exceed the standard value. If the temperature exceeds this value, the thermostat switches off the backup electrical heater. Switching on is done manually by qualified staff, after analysing the reasons for the switch off.

##### 4.1.3. Temperature Probe

The purpose of the temperature probe is to measure the temperature values of water in the storage water heater in order to control the system.

##### 4.1.4. Expansion Vessel\*

The expansion vessel is a device whose purpose is to compensate for the increase in water volume due to temperature rise.



The placement of this device is a recommended procedure for a correct installation of the equipment.  
Installation of this device is the responsibility of the installer.  
As a general rule, it is installed in the cold water pipe.

#### 4.1.5. Safety Group\*

The safety device allows the system to be protected against anomaly situations: cold water supply, hot water flowing back, emptying of the storage water heater and high pressure. The valve is calibrated to activate at 0.7 MPa).

To drain the water in the storage water heater, you should close the supply valve and open the discharge valve.

The safety valve discharge pipe must be open into the atmosphere, because the valve may drip water or even discharge water.

The safety valve must be opened regularly to remove impurities and check that it is not blocked. The discharge pipe must be installed in a vertical position. The discharge pipe must be installed upright away from a cold environment.



Installing this device is recommended **as mandatory** for the proper installation of the equipment. Installing this device is the responsibility of the installer.  
As a general rule it is installed in the cold water pipe.

#### 4.1.6. Pressure Reducing Valve\*

The pressure reducing valve must always be installed upstream from the safety device, and ready to activate in situations when the pressure in the circuit exceeds 3 bar (0.3MPa). This valve comes with a pressure gauge.

**\*Parts not supplied by the manufacturer. They must be installed by the installer.**

## 4.2. Positioning



Before starting to assemble the equipment, check the support capacity of the wall and the material it is made of, considering the weight of the equipment filled with water.

When placing the equipment in its position, bear in mind possible future interventions. Make sure that there is at least the following free space around the equipment:

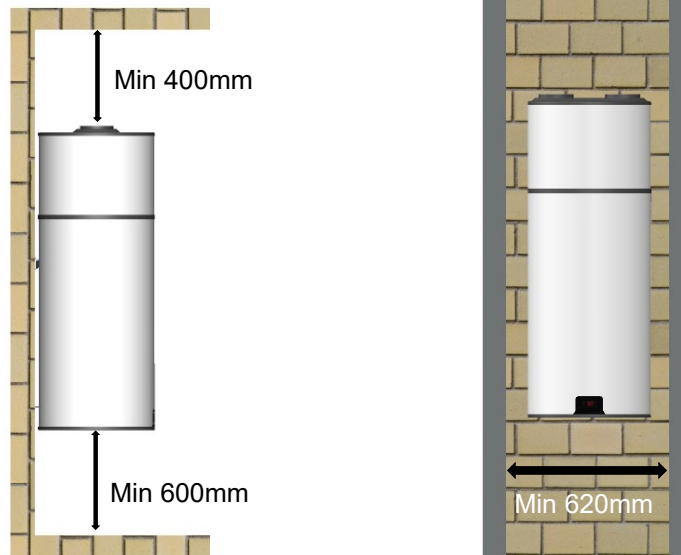

Adjust the levelling feet of the equipment. An inclination angle of up to 1° tilting backwards is acceptable.



If equipment tilts other than backwards, this will cause condensates to deposit in the tank.

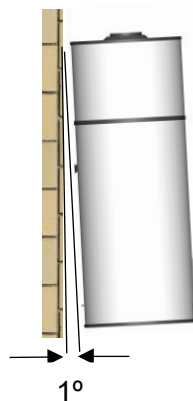
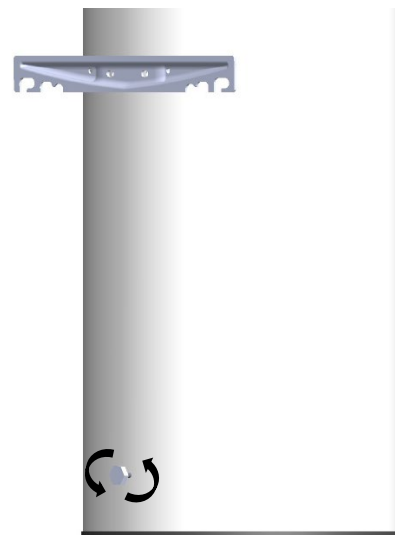

### 4.3. Air Inlet/Outlet Installation



As the AquaPura Monobloc absorbs heat during its operation, the air flow (inlet/outlet) must be directed to unheated areas. The equipment will cool the room where it is placed and so if it is installed in heater rooms, the air flow must be directed to other rooms and/or the outside.

#### 4.3.1. Installation without Ducts

The **AquaPura Monobloc** equipment must be installed in a place that is not too heated, and may be used for dehumidifying and cooling these rooms (e.g., laundries, cellars, etc). Distance between the top of the unit and the ceiling must be no less than 600mm.

If the distance between the unit and the ceiling is less than 600mm, two elbow-type joints must be installed as shown in the following picture.

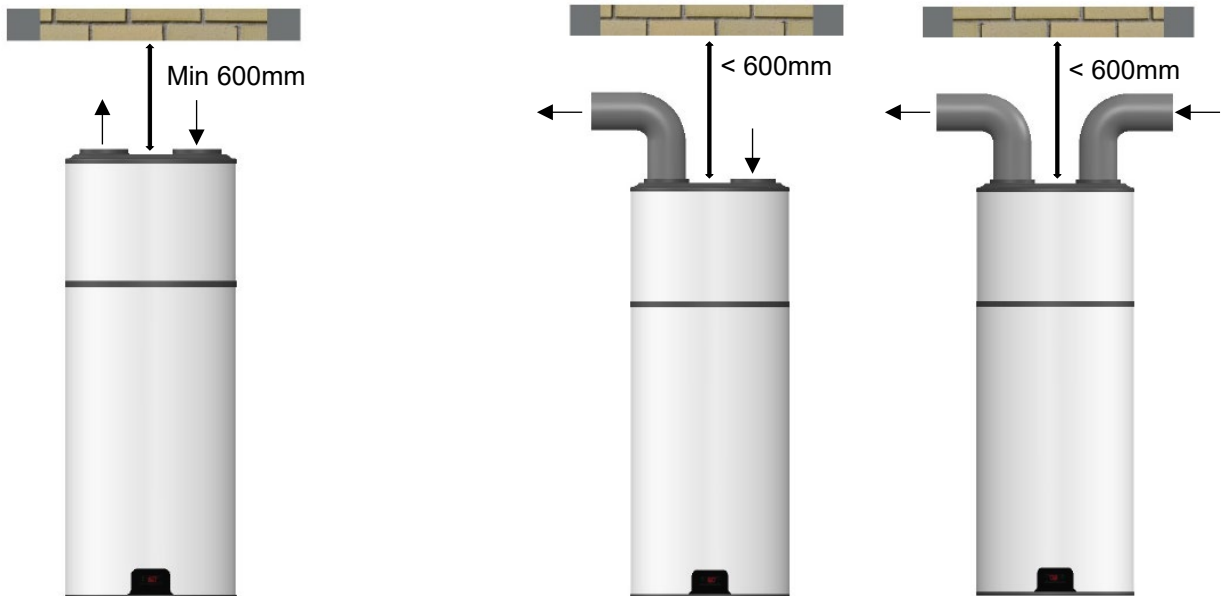

#### 4.3.2. Installation with Ducts

The AquaPura Monobloc is prepared to install ducts with diameter of 125 mm and 150 mm, in its air intake and extraction zones:

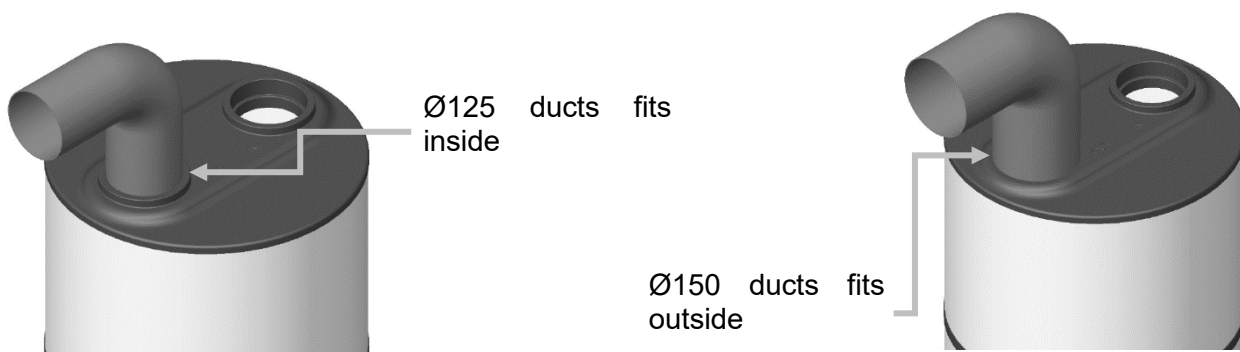



		Max Length Ducts	
		Ø125	Ø150
Rigid duct <sup>1)</sup>	m	10	20
Flexible duct <sup>1)</sup>	m	6	12

1) Considering 90° curves and louvers at the air inlet and outlet of the equipment.

If ducts are used, directing the air flow to areas that do not require heating, there are some options:

**Using Outside Air**

If outside air is used, the unit may be placed either in a heated room or in an unheated room.

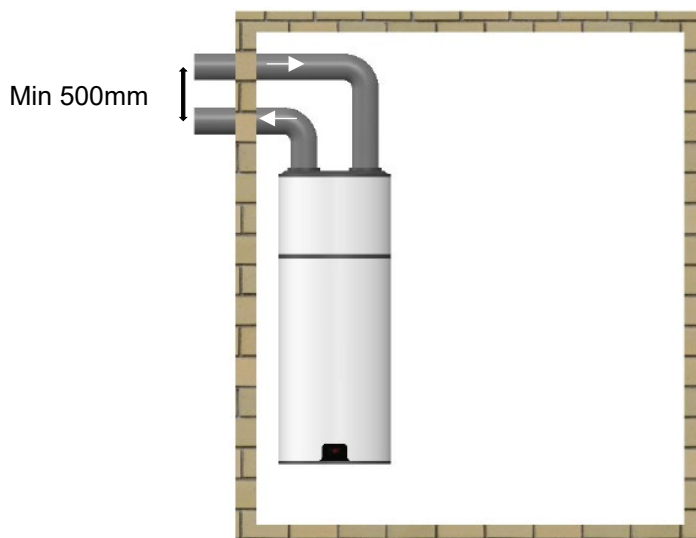

**Using Ambient Air**

The monobloc unit may also be placed in a heated room, but the air flow must be directed to an unheated room. Bear in mind that because of air flow, cooling the unheated room can affect the adjacent heated rooms.

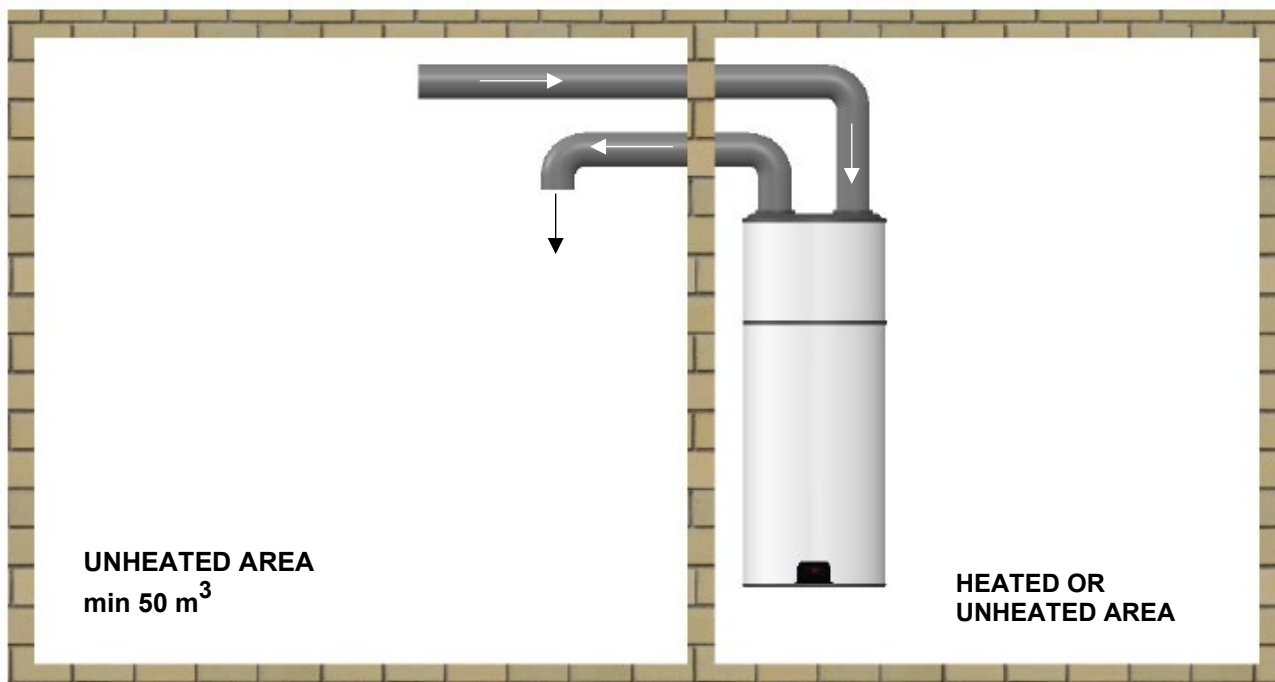

**Using Ambient and Outside Air**

A branched duct can be used to inflate air into the equipment. So you can get hot air in the summer, from the outside, and hot air in the winter from an unheated room.

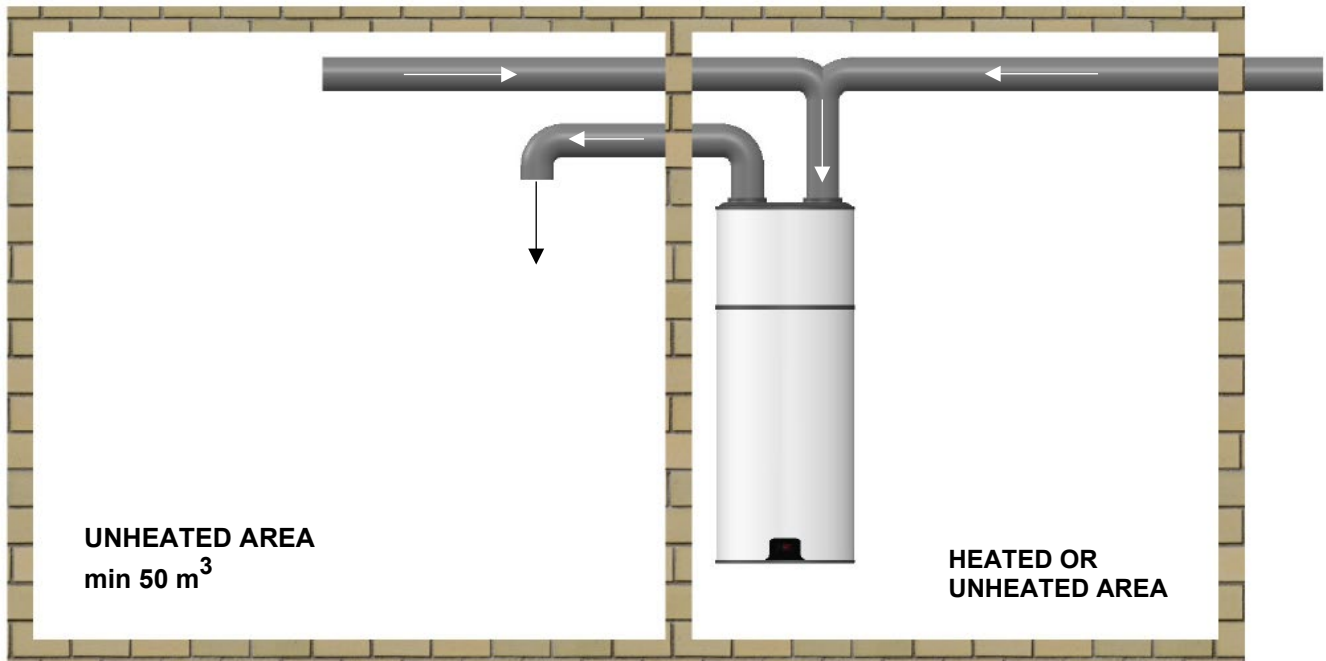

Ducts used to direct the airflow are not included in the equipment, and it is up to the installer to install them, if necessary, to comply with the manufacturer's recommendations.  
 Diameter of pipes must be of 125 mm or 150mm.  
 Pipes must not exceed 20 m in length.

#### 4.4. Hydraulic Installation

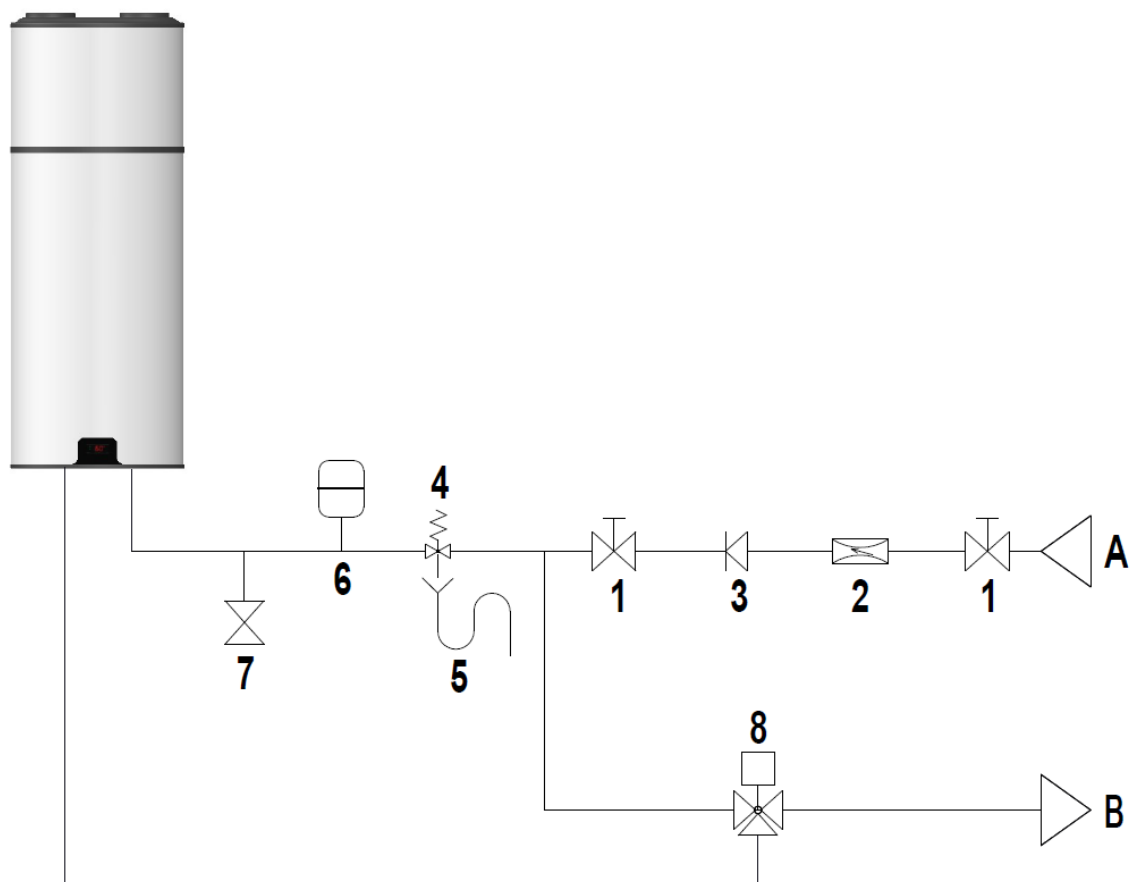

##### Caption

- |                                             |                              |
|---------------------------------------------|------------------------------|
| 1 Shut Off Valve                            | 6 Expansion Vessel           |
| 2 Pressure Reducing Valve (3 bar / 0,3 MPa) | 7 Drain Valve                |
| 3 Non-return Valve                          | 8 Electrostatic mixing valve |
| 4 Safety group (7 bar / 0,7 MPa)            | A Cold Water Inlet           |
| 5 Drainage Siphon                           | B Hot Water Outlet           |



It is necessary to install a safety device at the cold water inlet of the appliance. The safety device must be in compliance with the standard EN 1487:2002, maximum pressure 7 bar (0.7 MPa) Water must not be stopped from flowing from the safety device to the deposit by any sort of accessory.

The safety device must be connected with piping whose diameter is not less than the cold water inlet coupling. The discharge must be connected to a sewage siphon or, if this is not possible, elevated to a distance of at least 20 mm from the pavement to allow visual inspection;

To prevent high pressure from main water supply, install a pressure reduction valve set to 3 bar (0.3 MPa).



The Manufacture is not responsible for damage related to not following these recommendations/ warnings.



The water you use may contain impurities and/or substances damaging to the system and even harmful to your health. Make sure you use water with quality fitting for home consumption. The following table indicates some parameters that, when exceeded, must be chemically treated.

Hardness (°dH)	pH	Treatment
3,0 - 20,0	6,5 - 8,5	No
3,0 - 20,0	<6,5 - >8,5	Yes
<3,0 - >20,0	-	Yes

### 4.5. Thermodynamic Group Access

To access the equipment machine it is necessary to remove the helmet (covering the upper part). If the installation local has space restrictions that do not allow the helmet to be removed from above and whose possible access to the machine is only frontal, the following disassembly and assembly procedure must be followed:

1. Disengage the air insufflation and extraction ducts from the top of the equipment;
2. Unscrew the two fastenings on the front of the equipment, lift the helmet slightly and turn the helmet 180°;
3. Unscrew 2 of the fasteners (on the same side) from the helmet union;
4. With the helmet open, rotate again 180° to remove the helmet from the front.
5. To assemble the helmet, exactly the same steps mentioned must be carried out in reverse.

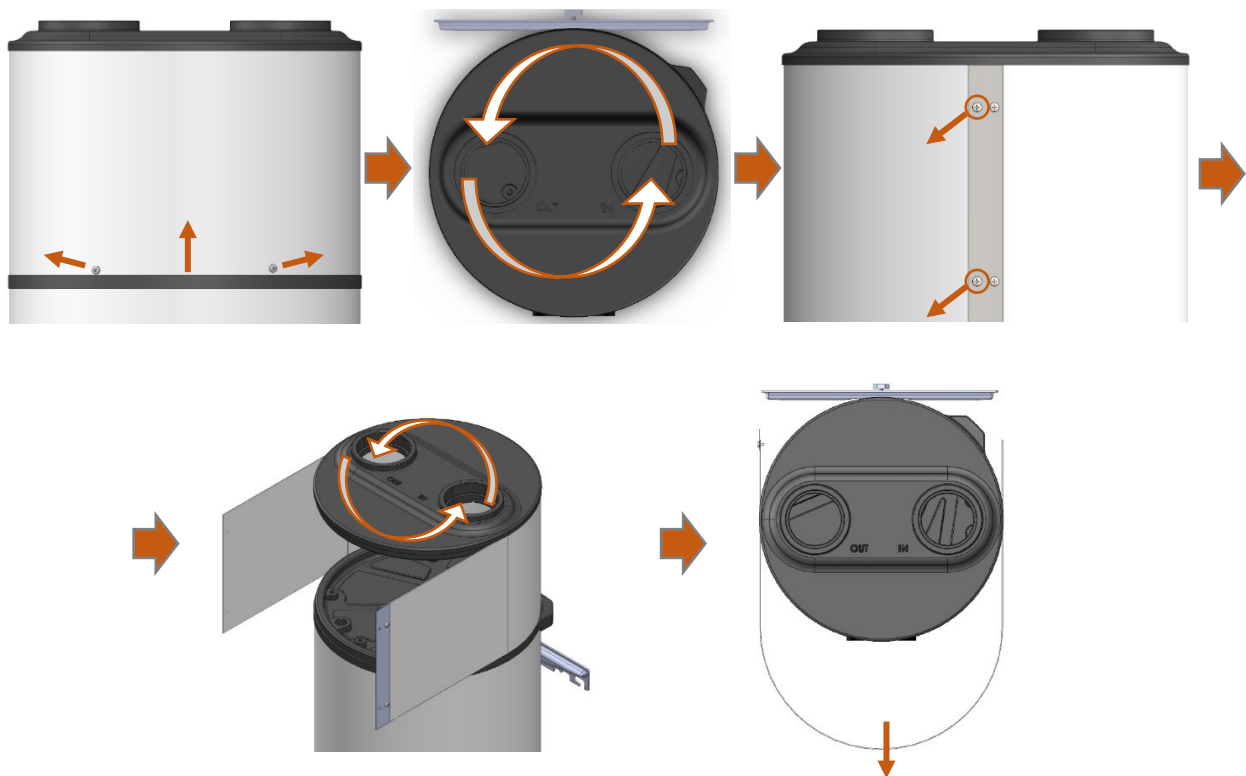

## 4.6. Condensates

During operation, condensation may occur. These condensates are collected in the drip tray and drained through a hole at the back of the tray. The installer must connect the condensate hose supplied by the manufacturer and direct the condensates to the drainage system or drainage siphon.



The condensate hose must not be bent/pressed and must be placed where it best suits the proper flow of condensates.

## 4.7. Electrical Connections

The thermodynamic equipment must be plugged to the power supply only after filling the storage water heater. The thermodynamic equipment comes with a mains cable, to be connected to an earthed monophase voltage (230VAC/50HZ). The connections must comply with the standards of installation in effect in the territory or country where the thermodynamic equipment has been installed. The installation includes:

- Bipolar circuit-breaker with connection cable with section equal to or exceeding 2.5 mm
- Protection differential circuit breaker of 30 mA

If the power supply cable is damaged, it must be replaced by the manufacturer, by its customer service, or by staff with similar training.

### 4.8. Electrical Diagram

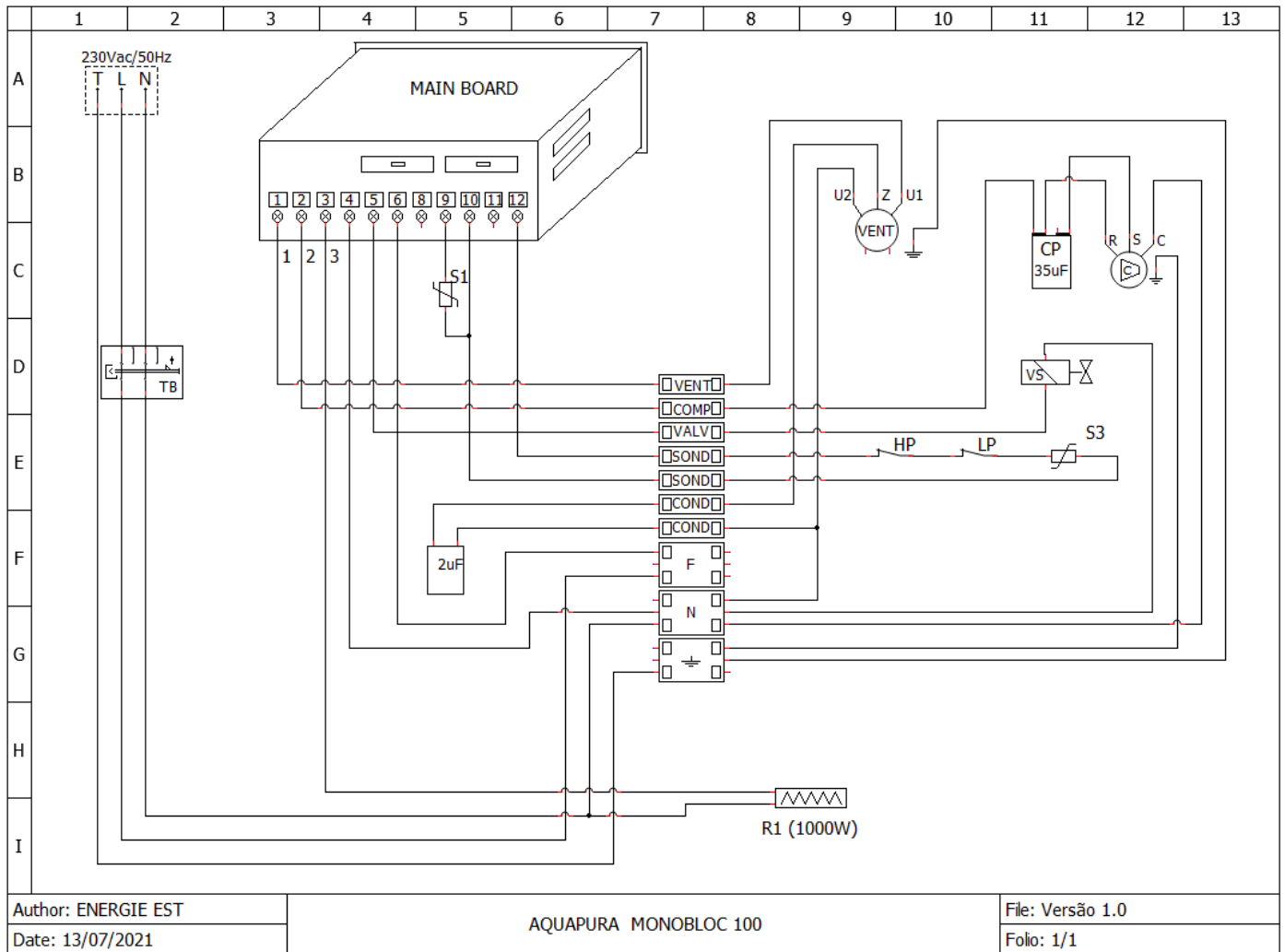

**CAPTION**

- |                                                                                                                                                                                                       |                                                                                                                                                                          |
|-------------------------------------------------------------------------------------------------------------------------------------------------------------------------------------------------------|--------------------------------------------------------------------------------------------------------------------------------------------------------------------------|
| <p><b>R1</b> Electrical backup heater</p> <p><b>S1</b> Water temperature probe</p> <p><b>S3</b> Evaporator temperature probe</p> <p><b>VENT</b> Fan</p> <p><b>N</b> Neutral</p> <p><b>F</b> Phase</p> | <p><b>HP</b> High pressure switch</p> <p><b>LP</b> Low pressure switch</p> <p><b>C</b> Compressor</p> <p><b>TB</b> Safety thermostat</p> <p><b>SV</b> Solenoid valve</p> |
|-------------------------------------------------------------------------------------------------------------------------------------------------------------------------------------------------------|--------------------------------------------------------------------------------------------------------------------------------------------------------------------------|

## 5. CONTROL and PROGRAMMING

### 5.1. Control Panel

The control panel is simple and intuitive. Allows the configuration of various operating parameters depending on the operating mode selected by the user.





### 5.2. Keys (Functions)

Key	Description
	ON/OFF Switch on and off controller; Exit menu, submenu or cancel a function;
	Unlock keyboard; Enter parameter menu; Confirm parameters within menus or submenus;
	Manual activation of the defrosting cycle (the defrosting function will only start if the defined conditions to the beginning of the cycle are satisfied); Pointer to increase values.
	Select operation mode; Pointer to decrease values.

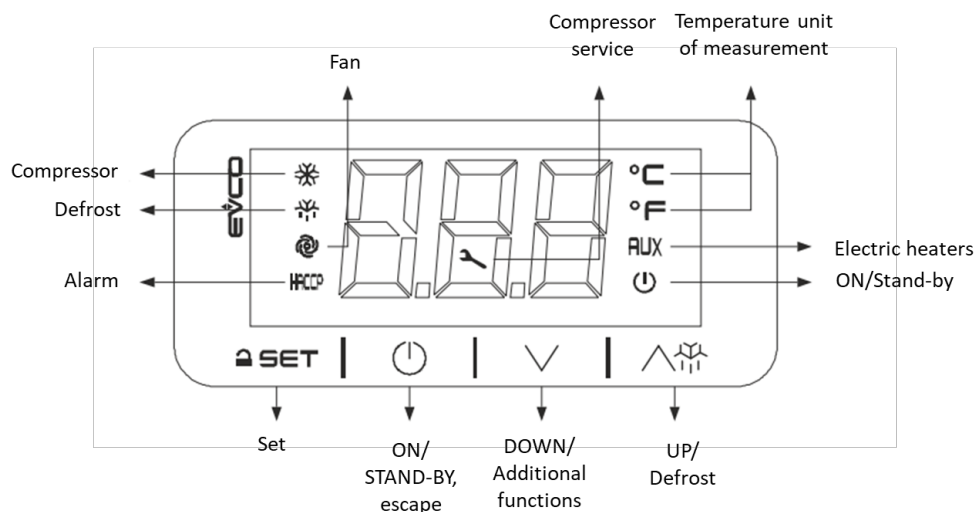
### 5.3. Display



Led	Description
	Compressor's led; If the led is: <ul style="list-style-type: none"> <li>On, the compressor is functioning;</li> <li>Blink, the compressor is temporizing to start.</li> </ul>
	Defrost cycle active

	Fan's led; If the led is: <ul style="list-style-type: none"> <li>• On, the fan is functioning;</li> <li>• Blink, the fan is temporizing to start.</li> </ul>
<b>AUX</b>	Electrical resistance of functioning support
	Maintenance led, verify compressor
°C	Information on the display in Celsius degrees
°F	Information on the display in Fahrenheit
<b>HACCP</b>	Alarm indication led
	ON/OFF equipment. If the led is: <ul style="list-style-type: none"> <li>• On means that the equipment is off;</li> <li>• Off means that the equipment is on.</li> </ul>

### 5.4. User Interface

The heat pump is programmed to work in three modes of operation:

**ECO (ECONOMY)** operating mode, the equipment works only as a heat pump to heat the water in the water heater. The operating setpoint adopted corresponds to parameter **SP1**.

During ECO operating mode the compressor works in parallel with the fan and the electrical heater is always off unless if it is needed during a defrost cycle.

**NOTE:** In ECO mode we obtain greater efficiency, allowing greater savings for the user.

**AUT (CONFORT)** operating mode, the equipment works as a heat pump plus electrical heater to heat the water in the water heater. The operating setpoint adopted by the compressor and the electrical heater corresponds to parameter **SP2**.

During **AUT** operating mode the compressor works in parallel with the fan and the electrical heater.

**OBS (BOOST)** operating mode the equipment works as a heat pump plus electrical heater to heat the water in the water heater. The operating setpoint adopted by the compressor and the electrical heater corresponds to parameter **SP1**.

During **OBS** operating mode the compressor works in parallel with the fan and the heater.

**NOTE 1:** The OBS operating mode lasts for one cycle if the operating mode prior to the mode change is ECO mode, that is, after active and reaching the respective setpoint (SP1), it is automatically cancelled and the equipment assumes by default the previous operating mode (ECO).

**NOTE 2:** In ECO mode it is only possible to activate the OBS function when the water temperature in the water heater is lower than SP3.

**NOTE 3:** If the OBS operating mode is active during the AUT operating mode, the equipment will work alternately between AUT mode and OBS mode, that is, if the water temperature drops to below SP3 the controller assumes the OBS function until reaching the SP2 setpoint. If the water temperature remains above SP3 the controller assumes AUT mode.



## 5.5. User interface

### 5.5.1 - ON/OFF equipment

Press the  key during 4 seconds to switch on or off the equipment

Note: After turning on the equipment, you must wait 5 minutes until the equipment starts (delay of compressor start)

### 5.5.2 – Lock/unlock the keypad





To unlock the keypad press any key during 1 second and the display will show the label “UnL”. The keypad is automatically locked after 30s of inactivity on the keypad. When the keypad is blocked the message “Loc” is presented on the display.

### 5.5.3 – Information on the display during working time





During working time, the water temperature is presented on the display

### 5.5.4 – Information on the display during working time

It is possible to check the total amount of time that the compressor is on and also to reset this count by following these steps:

- Check that the keypad is not locked (check 5.5.2, regarding unlocking the keypad)
- Press the  key and the display will show the following code:
  - CH – Show the total amount of time the compressor is on in hundreds of hours
  - rCH – Delete the current count of compressor working hours
- Use the  and  to select the desired code
- Press the  **SET** key to show the current amount of hours the compressor is working with the code CH or reset the counter of compressor working hours.

If the code rCH is selected, a few extra steps are needed to reset the counter:

- Use the  and  to select the value “149”.
- Press the  **SET** key to reset the counter
- Press the  key to get back to the main screen with no other changes

### 5.5.5 – Changing working modes





To check the currently selected mode press the  key and automatically the display will show the current mode where the following code may be shown

Code	Description
ECO	Economy
Aut	Comfort
obS	Overboost
Ant	Anti-legionella
dEF	Defrost
In2	Photovoltaic function

#### 5.5.5.1 – ECO mode





To activate the ECO mode, follow the next steps:

- Make sure the keypad is not locked (check 5.5.2, regarding unlocking the keypad) and that no other advanced functions are active such as defrost and the overboost mode is not active.

- Press the  key during 2 seconds until the current the current active mode text starts to blink.
- Use the  and  keys to select the ECO mode
- Use the  SET key to activate the ECO mode
- Press the  key to get back to the main screen with no other changes





### 5.5.5.2 – AUT mode

To activate the AUT mode, follow the next steps:

- Make sure the keypad is not locked(check 5.5.2, regarding unlocking the keypad) and that no other advanced functions are active such as defrost and the overboost mode is not active.
- Press the  key during 2 seconds until the current the current active mode text starts to blink.
- Use the  and  keys to select the AUT mode
- Use the  SET key to activate the AUT mode
- Press the  key to get back to the main screen with no other changes

### 5.5.5.3 – OBS mode

To activate the OBS mode, follow the next steps:





- Make sure the keypad is not locked(check 5.5.2, regarding unlocking the keypad) and that no other advanced functions are active such as defrost.
- Press the  key during 2 seconds until the current the current active mode text starts to blink.
- Use the  and  keys to select the OBS mode
- Use the  SET key to activate the OBS mode
- Press the  key to get back to the main screen with no other changes

### 5.5.6 – Setpoints

There are 3 setpoints for each of the modes of the pump heater which are displayed in the table below:





Parameter	Description
SP1	Compressor setpoint in <b>ECO</b> mode. Compressor and electric heater setpoint on the <b>OBS</b> mode if the <b>OBS</b> mode is activated when <b>ECO</b> was previously activated.
SP2	Compressor and electric heater setpoint in <b>AUT</b> mode. Compressor and electric heater setpoint in <b>OBS</b> mode if the <b>OBS</b> is activated when <b>AUT</b> was previously active
SP3	Setpoint to activate de <b>OBS</b> mode. This mode will only activate if the water temperature in the tank is lower than <b>SP3</b>

#### 5.5.6.1 – Change ECO mode setpoint (SP1)





- Check that the keypad is not locked (check 5.5.2, regarding unlocking the keypad)
- Press the  SET key and the parameter “SP1” will show on the display
- Press the  SET key again to display the current value assigned to “SP1”
- Use the  or  keys to increase or decrease the temperature to the desired value.

- Press the **SET** key again to define the setpoint to the selected temperature
- Press the  key to get back to the main screen with no other changes

### 5.5.6.2 – Change AUT mode setpoint (SP2)

- Check that the keypad is not locked (check 5.5.2, regarding unlocking the keypad)
- Press the **SET** key and the parameter “SP1” will show on the display
- Use the  or  keys to find the “SP2” parameter on the display
- Press the **SET** key again to display the current value assigned to “SP2”
- Use the  or  keys to increase or decrease the temperature to the desired value.
- Press the **SET** key again to define the setpoint to the selected temperature
- Press the  key to get back to the main screen with no other changes

### 5.5.6.3 – Change OBS mode setpoint (SP3)

- Check that the keypad is not locked (check 5.5.2, regarding unlocking the keypad)
- Press the **SET** key and the parameter “SP1” will show on the display
- Use the  or  keys to find the “SP3” parameter on the display
- Press the **SET** key again to display the current value assigned to “SP3”
- Use the  or  keys to increase or decrease the temperature to the desired value.
- Press the **SET** key again to define the setpoint to the selected temperature
- Press the  key to get back to the main screen with no other changes

## 5.6. Anti-Legionella Function

The electronic control is enabled with the Anti-Legionella function, which consists of a water heating cycle up to 65 °C for a suitable period of time to prevent the formation of germs in the tank. The Anti-Legionella function is automatically activated every 30 days.



## 5.7. Desfrost function







This function allows the removal of frost in the evaporator which reduces the heat transmission to the heat pump. It is automatically activated when the temperature of the evaporator is below accepted levels disactivating the compressor and turning on the electric heaters.

## 5.8. Photovoltaic function

This function when activated, turns on the compressor and electric heaters to take advantage of photovoltaic energy and uses a different temperature setpoint stored in the parameter “SP6”. To activate this function and change the value in “SP6” you must access the controller parameters using the steps on 5.8.1. This function, when it is activated, can only be deactivated manually by the user modifying the parameters.

### 5.8.1 – Activate the photovoltaic function













- Check that the keypad is not locked (check 5.5.2, regarding unlocking the keypad)
- Press the **SET** during 4 seconds and the display will show the label “PA”
- Press the **SET** key again
- Use the  or  keys to input the code “-19”
- Press the **SET** key again

- Use the  or  keys to scroll the parameters and find the “i3”
- Press the  SET to display the current value of “i3” parameter
- Use the  or  keys to input the value “1” on the parameter to activate the photovoltaic function
- Press the  SET key to confirm this new value on “i3”
- Press the  key to get back to the main screen with no other changes

## 5.9. Parameter configuration

To access the controller parameters of the heat pump, follow the steps on 5.9.1.

### 5.9.1 – Access controller parameters

- Check that the keypad is not locked (check 5.5.2, regarding unlocking the keypad)
- Press the  SET during 4 seconds and the display will show the label “PA”
- Press the  SET key again
- Use the  or  keys to input the code “-19”
- Press the  SET key again
- Use the  or  keys to scroll through the parameters
- Press the  SET key to select a parameter and check its current value
- Use the  or  keys to modify the currently selected parameter
- Press the  SET key to confirm the inputted value.
- Press the  key to get back to the main screen with no other changes

### 5.9.1 – Controller parameters

Parameters	Value	Heat pump setpoints	Limits	
			Min	Max
SP1	52	Setpoint in economy mode	r3	r4
SP2	55	Setpoint in comfort mode	r1	r2
SP3	45	Overboost activation threshold	10°	r2
SP5	55	Heat pump switch-off threshold	r1	SP2
SP6	65	Photovoltaic system setpoint	40°	100°
SP7	5	Setpoint in antifreeze mode	0°	40°
SP8	40	Setpoint in green mode	0°	100°
SP9	-7	Cold evaporator alarm threshold	-25°	25°
SPA	-25	Evaporator failure alarm threshold	-50°	25°
Parameters	Value	Analog inputs	Limits	
			Min	Max
CA1	0	DHW tank upper probe offset	-25°	25°
CA2	0	DHW tank lower probe offset	-25°	25°
CA3	0	Evaporator probe offset	-25°	25°
PO	1	Type of probe	0=PTC 1=NTC 2=PT 1000	
P1	0	Enable decimal point °C	0=No 1=Yes	

P2	0	Temperature measurement unit	0=°C 1=°F	
P3	0	Probe configuration	0=DWH tank upper probe and high-pressure input 1=DWH tank upper and lower probe	
P4	1	Evaporator probe configuration	0=Disabled (defrost every d18 minutes) 1=Defrost activation and defrost end 2=Defrost activation	
P5	0	Displayed value	0=DWH tank upper probe temperature 1=Setpoint of AUT/ECO modes 2=DWH tank lower temperature 3=Evaporator temperature	
P8	5	Display refresh time	0 (1/10s)      250(1/10s)	
Parameters	Value	Regulation	Limits	
			Min	Max
r0	5	Setpoint differential	0.1°	30°
r1	40	Minimum setpoint in comfort mode	10°	r2
r2	70	Maximum setpoint in comfort mode	r1	100°
r3	40	Minimum setpoint in economy mode	10	r4
r4	55	Maximum setpoint in economy mode	r3	100°
r5	0	Enable setpoint blocking in economy and comfort modes	0=No 1=Yes	
r6	15	Heater threshold in comfort mode	0°	50°
r7	15	Heater threshold differential in comfort mode	1°	30°
Parameters	Value	Compressor	Limits	
			Min	Max
C0	1	Compressor on delay from power-on	0 min	240 min
C1	5	Minimum time between two power-ons of the compressor	0 min	240 min
C2	5	Minimum compressor-off time	0 min	240 min
C3	0	Minimum compressor-on time	0 s	240 s
C10	0	Compressor hours for maintenance	0(0=disabled)	999(h x 100)
C11	0	Interval for cold evaporator control	0 min	999 min
C12	60	Compressor-on delay from fan on for cold evaporator control	0 s	240 s
C13	20	Compressor-on delay from green multi-purpose input reset	0 min	240 min
C14	20	Compressor-on consecutive time for evaporator failure control	-1 min (disabled)	20 min
Parameters	Value	Defrost	Limits	
			Min	Max
d1	1	Type of defrost	0=Electric 1=Hot gas 2=Compressor stopped 3=Hot gas balancing pressure	
d2	10	Defrost end threshold	-50°	50°
d3	10	Defrost duration	0 min	99 min
			0= Defrost disabled If P4=1, the maximum duration is 0(it is controlled by the probe)	
d17	-6	Evaporation temperature threshold for defrost interval count	-50°	50°
d18	15	Defrost delay	0 min (0=Manual defrost only)	240 min

Parameters	Value	Alarms	Limits	
			Min	Max
A0	0	Value for low temperature alarm	0=DHW tank upper temperature 1=DHW tank lower temperature 2=Evaporator temperature probe	
A1	5	Low temperature alarm threshold	0°	50°
A2	1	Low temperature alarm type	0=Disabled 1=Absolute	
A3	0	Value for high temperature alarm	0=DHW tank upper temperature 1=DHW tank lower temperature 2=Evaporator temperature probe	
A4	80	High temperature alarm threshold	0°	199°
A5	1	High temperature alarm type	0=Disabled 1=Absolute	
A6	0	High temperature alarm delay from power-on	0 min	240 min
A7	0	High/low temperature alarm delay	0 min	240 min
A11	3	High/low temperature alarm differential	1°	30°
Parameters	Value	Fan	Limits	
			Min	Max
F0	1	Fan configuration	0=Activated 1=Disabled	
Parameters	Value	Anti-Legionella	Limits	
			Min	Max
H0	30	Anti-legionella interval	0 days (0=None)	99 days
H1	65	Anti-legionella thermal threshold	10°	199°
H3	2	Anti-legionella thermal threshold maintenance duration	0 min (0=Function disabled)	240 min
Parameters	Value	Digital inputs	Limits	
			Min	Max
i0	1	Multipurpose input function	0=Disabled 1=Pressure switch 2=Green function	
i2	5	Compressor-on delay from pressure switch alarm reset	0 min	120 min
i3	0	Enable photovoltaic system	0=No 1=Yes	
i4	1	Photovoltaic system input activation	0=Closed contact 1=Open contact	
i5	0	High pressure input activation	0=Closed contact 1=Open contact	
i8	0	Number of pressure switch alarms for unit blocked alarm	0 (0=Disabled)	15
i9	240	Counter reset time for pressure switch alarms	1 min	999 min
i10	0	Pressure switch alarm from compressor-on	0 sx10	240 sx10
i11	60	Time pre-opening hot gas defrost valve	0 s	240 s
i12	1	Fan off during pressure switch/unit blocked alarm	0=No 1=Yes	
Parameters	Value	Digital inputs	Limits	
			Min	Max
u0	1	Enable K2 and K4 relay inversion	0=No (Defrost on K2) 1=Sim (Defrost on K4)	

u9	1	Enable alarm buzzer	0=No 1=Yes
----	---	---------------------	---------------

## 6. ERRORS

The installation, assembly and repair of the equipment can only be carried out by qualified technicians.

Symbols	Description	Problem / Checking
<b>Pr1</b>	Probe 1 damaged	Check integrity of probe connections on the controller; Measure probe resistance (NTC 10K $\Omega$ , resistance at 25°C equals $\pm$ 10K $\Omega$ ); Replace probe;
<b>Pr2</b>	Probe 2 damaged	
<b>Pr3</b>	Probe 3 damaged	
<b>rtc</b>	Alarm time setting	Set the time, date and day of the week;
<b>AL</b>	Temperature too low	Temperature in the water heater below 10°C.
<b>AH</b>	Temperature too high	Shorted probe: Check integrity of probe connections on the controller; Measure probe resistance (NTC 10K $\Omega$ , resistance at 25°C equals $\pm$ 10K $\Omega$ ); Replace probe;
<b>PF</b>	Power failure alarm	Click on a random button; Check electrical connections.
<b>LHP</b>	Pressure switch alarm	Turn the equipment off and on.
<b>HP</b>	High pressure alarm	Turn the equipment on and off. Check electrical connections. Obstruction in the refrigeration circuit.
<b>FiL</b>	Compressor maintenance alarm	Turn the equipment on and off.
<b>UtL</b>	Evaporator failure alarm	Turn the equipment on and off.

## 7. PROBE CHART

The probes installed in the equipment, probe S1, S2, S3, are of the NTC 10kΩ@25°C type.

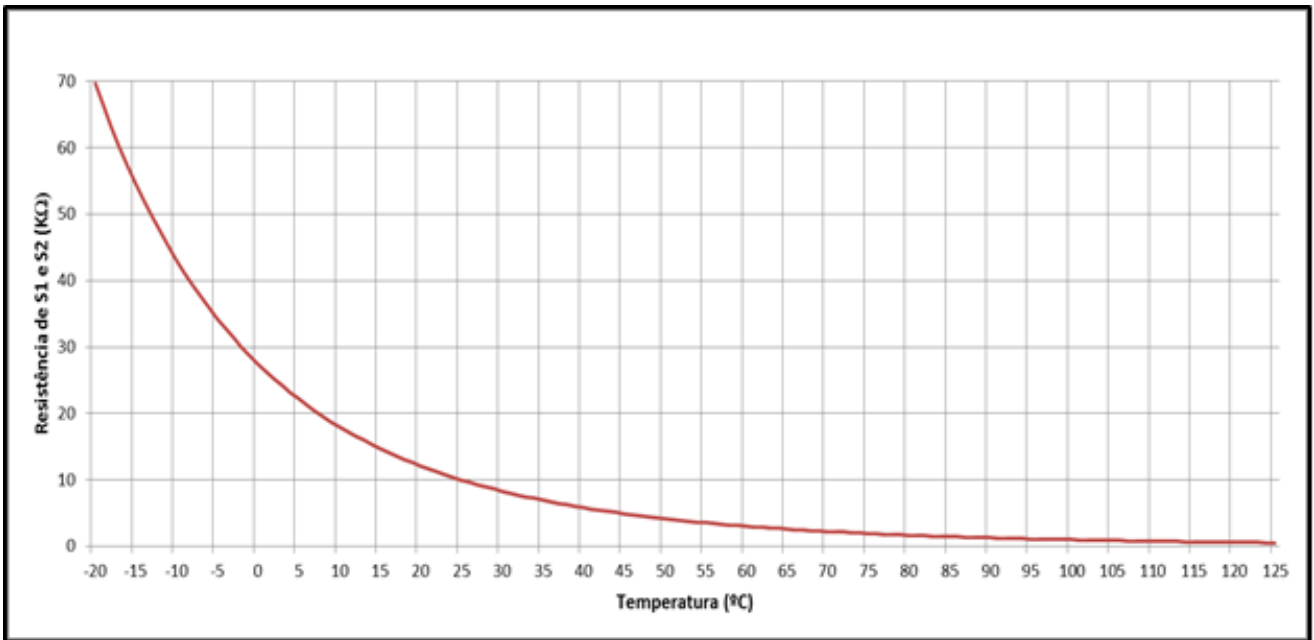





## 8. TROUBLESHOOTING

Problem	Possible Causes	How to Proceed
Failure in electronic board	Falta de alimentação	Check the power supply. Check the corresponding circuit breaker.
	Cable damaged or disconnected	Check the integrity of the electronic board's electric circuit.
Low water temperature or lack of hot water	Low temperature programmed as the set-point	Adjust the temperature of the set-point. 55°C from factory.
	Error activation	Check the presence of error on electronic board and consult the table of errors.
	Cable damaged or disconnected	Check the connection of equipment to the plug Check that the corresponding circuit-breaker is connected. Check the integrity of the cables. Check that the electrical cable is disconnected from the power board. Check electric protection (fuse).
	Equipment or compressor off	See chap. 5.4 for starting the equipment.
	Use of large amount of hot water	Change the equipment to "OBS" mode for a fast water heating.
	Return of hot water into the cold water circuit (safety device incorrectly installed or damaged)	Shut off the cold water supply valve to switch off the safety device. Open a hot water tap. Wait 10 minutes and if you get hot water, replace the faulty plumbing and/or proceed with the correct positioning of the safety device. Clean the filter of the safety device.
	ECO mode selected and external temperature really low	Change the equipment to "AUT" mode to start automatic management of system Change the equipment to "OBS" mode for a fast water heating.
	Electric heater OFF	Make sure the backup electric heater has power supply.
Water is too hot and/or there is steam	Problem with the probe	Check error display on electronic board
	Problem with the safety thermostat	Check correct running of safety thermostat
Reduced operation of the heat pump circuit and consequently activated resistance, in "Aut" mode	Extremely low ambient temperature	The operation of the equipment depends on the weather conditions.
	Low inlet water temperature	The operation of the equipment depends on the temperature of the inlet water.
	Installation with low electrical voltage	Make sure that the indicated voltage value is supplied to the installation.
	Problems in the heat pump system	Check the display for an error continuously.
	Clogged or frozen evaporator	Clean the evaporator.
	Fan Problems	Check wiring status.

<b>Problem</b>	<b>Possible Causes</b>	<b>How to Proceed</b>
Low hot water flow rate	Hydraulic circuit blocked	Check the condition of the hydraulic circuit
Water leakage by the security group	Absence or poor sizing of the expansion vessel (if leakage is intermittent)	Installation and/or correct sizing of an expansion vessel
	High pressure in the network (if leakage is continuous)	Checking the pressure reducing valve (if fitted). Installation of a pressure reducing valve (if absent).
Abnormally high and constant electrical consumption	Losses or obstruction in the refrigerant circuit	Check that the piping is not damaged. Use proper equipment to check leaks in the circuit.
	Adverse environmental conditions	
Electrical heater doesn't work	Safety thermostat failure or activation	Check the safety thermostat.
	Electrical heater damaged	Check the electrical heater
Bad odor	Absence of siphon or waterless siphon	Install and certify the syphon has water.
Undrained Condensates	Clogged condensate evacuation system	Clean the condensation circuit
	Clogged condensate drain pipe	Check the drain pipe
Magnesium anode degradation	Over time, the magnesium anode will be consumed. This consumption is normal, resulting of scarification to prevent corrosion of the tank. The consumption rate differs depending on the quality of your water. Is recommended to check the status of your anode at least every year.	

## 9. SYSTEM MAINTENANCE

 <b>WARNING</b>	<p>Before undertaking any maintenance operation on the equipment, make sure it is not plugged to the power supply! Wait until the fan comes to a complete stop.</p>
-----------------------------------------------------------------------------------------------------	-------------------------------------------------------------------------------------------------------------------------------------------------------------------------

	<p>Although the fluid in the cooling circuit is environmentally-friendly, it must not be released into the atmosphere. Forms of recovery must be arranged.</p>
-----------------------------------------------------------------------------------	--------------------------------------------------------------------------------------------------------------------------------------------------------------------

### 9.1. General Inspection

During the equipment's useful life, the owner should carry out a general inspection of the equipment, according to the place where the equipment is set up:

- External cleaning of equipment and surrounding areas with a wet cloth;
- Visual inspection of the whole equipment, with the purpose of detecting possible leaks and damaged devices.

### 9.2. Empty the Water Storage

 <b>WARNING</b>	<p>Remember that the water in the storage water heater is at a high temperature, so there is an associated risk of burns. Before emptying the storage water heater, allow the water temperature to drop to a level that avoids burns.</p>
------------------------------------------------------------------------------------------------------	-----------------------------------------------------------------------------------------------------------------------------------------------------------------------------------------------------------------------------------------------

After ensuring the water temperature is at a safe level that will avoid burns, follow this procedure:

- Unplug the system from the power supply
- Shut off the water supply valve and open a hot water tap
- Open the system discharge valve

### 9.3. Filter of Reduction Valve

To periodically clean the filter of the reduction valve, you should:

- Shut off the water supply.
- Turn anti-clockwise until you remove tension from the spring
- Remove the handle
- Remove filter and clean

### 9.4. Condensate circuit

Make sure you check the condensate draining system and the drip tray in the maintenance and cleaning service routines of your system. Clean the drip tray used as it may contain accumulated dust from the out- side, which may obstruct the condensates drainage holes. Make sure the holes and the condensate outlet pipe are not obstructed.

### 9.5. Cleaning Air Circuit

Make sure the air inlet filters are not obstructed, if applicable. Inspect at least once a year. The evaporator may have deposited dust. Clean it also, but be careful with its fins.

 <b>WARNING</b>	<p>The evaporator's fins are quite thin, so there is additional risk of injuries. Take care not to damage them.</p>
-------------------------------------------------------------------------------------------------------	-------------------------------------------------------------------------------------------------------------------------

### 9.6. Safety Thermostat

The safety thermostat is disarmed every time that an anomaly occurs in the system so if you wish to rearm it you must find out the cause of this disarm. If you cannot figure out the cause of the disarm you must contact our after-sale assistance to solve your case. If everything is as it should be and you wish to rearm the thermostat you should proceed in the following manner:

- Remove the lid below the equipment;
- Unscrew the lid of the thermostat (1);
- Press the button (2) to rearm the thermostat;
- Screw the thermostat lid back again (1) and place the lid again.

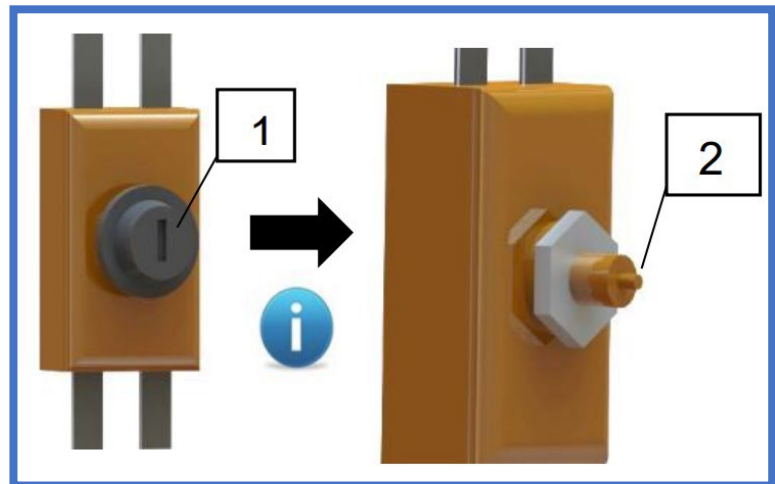

**EN  
D**



## Warranty

This warranty covers all defects to the confirmed materials, excluding the payment of any type of personal damage indemnity caused directly or indirectly by the materials.

The periods indicated below start from the purchase date of the apparatus, 6 months at the latest from the leaving date from our storage warehouses.

### Water Cylinder

#### (Domestic and Industrial)

5 Years: Stainless Steel (2+3 Years)\*

5 Years Enamelled (2+3 Years)\*

Manufacturer Warranty

### Thermodynamic

#### Solar Panel

10 years against corrosion

### Electrical components and moving parts:

- Thermodynamic Block
- Solar Block
- Solarbox
- Split
- Monobloc (except cylinder)
- Thermobox
- Inverter

2 Years

\*The warranty extension of 3 years, against corrosion of the internal tank (Enamelled / Stainless Steel), is conditioned to the submission of:

- Warranty and Check Sheet at maximum 15 days after the installation.
- Documental evidence of the magnesium anode annual replacement (if applicable).
- Pictures of the installation where it's shown safety group, expansion vessel, hydraulic and electrical connections.

In case of warranty, the parts replaced are property of the manufacturer. A repair under the warranty is not reason for an extension of its term.

### Warranty Exclusions

The warranty ceases to be effective when the apparatus is no longer connected, used or assembled in accordance with manufacturer instructions, or if there has been any form of intervention by unauthorized technicians, has the appearance of modifications and/or if the series number appears to have been removed or erased. The equipment should be installed by qualified technicians according to the rules in effects and/or the rules of the trade, or the instructions of our technical services. Further exclusions from warranty:

- Hot water tanks have been operating in water with the following indexes:
  - o Active chlorine > 0.2 ppm
  - o Chlorides > 50 mg/l (Inox)
  - o Hardness > 200 mg/l
  - o Conductibility > 600µS/cm (20°C)
  - o PH < 5,5 or PH > 9 (Sorensen at 20°C)
  - o Magnesium > 10 mg/l
  - o Calcium > 20 mg/l
  - o Sodium > 150 mg/l
  - o Iron > 1 mg/l
  - o If one of the water parameters has a higher value than stipulated by directive 236/98 (Portugal) or equivalent standard in the costumer's country
- Parts are subject to natural wear and tear – levers, switches, resistances, programmers, thermostats, etc.
- Breakdown due to incorrect handling, electrical discharges, flooding, humidity or by improper use of the apparatus.
- The warranty lapses if it is transferred to another owner, even if within the guarantee period.
- The warranty lapses if this certificate is incorrectly filled in, if it is violated or if it is returned after more than 15 days have passed since the installation or purchase date of the apparatus.

**NOTE:** This sheet must be properly filled, signed and stamped by the installer / reseller and returned to ENERGIE EST, Lda., otherwise the warranty will not be validated.

Send this installation sheet to [warranty@energie.pt](mailto:warranty@energie.pt), writing the serial number of the equipment as subject.













**ErP**  
READY

APPLIES TO  
SUBCLASS  
DIRECTIVE  
FOR ENERGY  
RELATED  
PRODUCTS



Informação mais detalhada em  
[energie.pt](http://energie.pt)



Siga-nos em  
**ENERGIE PORTUGAL**

**Morada** Zona Industrial de Laúndos, Lote 48  
4570-311 Laúndos - Póvoa de Varzim PORTUGAL  
**Coordenadas GPS** N 41 27.215', W 8 43.669'  
**Telefone** + 351 252 600 230

**Fax** + 351 252 600 239  
**E-mail** [energie@energie.pt](mailto:energie@energie.pt)  
**Web** [www.energie.pt](http://www.energie.pt)

Projeto co-financiado por:



UNÃO EUROPEIA  
Fundos Europeus  
Estruturais e de Investimento

O presente folheto foi criado apenas para informar e não constitui uma oferta contratual para a ENERGIE Est Lda. A ENERGIE Est Lda. compilou o conteúdo deste folheto de acordo com o melhor dos seus conhecimentos. Não é dada qualquer garantia expressa ou implícita no que toca à totalidade, precisão, fiabilidade ou adequação para um determinado fim do seu conteúdo e dos produtos e serviços que apresenta. As especificações estão sujeitas a alterações sem aviso prévio. A ENERGIE Est Lda. rejeita explicitamente quaisquer danos diretos ou indiretos, no seu sentido mais amplo, resultantes ou relacionados com a utilização e/ou interpretação deste folheto.

