



AQUAPURA MONOBLOC

200i | 200ix | 270i | 270ix | 300i | 300ix | 500ix



Esteemed Client,

We would like to thank you for your choice when you acquired an equipment for sanitary water heating.

AQUAPURA MONOBLOC aero-thermal system will surely meet all your expectations and provide many years of comfort with maximum power saving.

Our organization dedicates much time, energy and economic resources in order to develop innovations that will promote power saving in our products.

Your choice has demonstrated your good sense and concern with power consumption, a matter that affects the environment.





We have taken on a permanent commitment to conceive innovative and efficient products so that this rational use of energy can actively contribute to the preservation of the environment and natural resources of the planet.

Keep this manual whose objective is to inform, alert and advise about the use and maintenance of this equipment.

This instruction manual is also available on the website:"
<https://www.energie.pt/en/products/aquapura-monobloc>"

Our services are always at your disposal. Feel free to call upon us!

Index

1. INTRO	6
1.1. Symbols.....	6
1.2. Safety Information	6
1.3. Information.....	7
2. SPECIFICATIONS.....	9
2.1. Components	9
2.2. Running Principle	11
2.3. Technical Data	12
3. TRANSPORT.....	13
4. INSTALLATION.....	14
4.1. Safety and Control Devices	14
4.1.1. High/Low Pressure Switch.....	14
4.1.2. Safety Thermostat.....	14
4.1.3. Temperature Probe.....	14
4.1.4. Protection Against Corrosion (If Applicable).....	14
4.1.5. Expansion Vessel*	14
4.1.6. Safety Group*	14
4.1.7. Pressure Reducing Valve*	14
4.2. Drain pan	15
4.3. Positioning	15
4.4. Air Inlet/Outlet Installation	16
4.4.1. Installation without Ducts	16
4.4.2. Installation with Ducts.....	16
4.5. Hydraulic Installation	19
4.6. Condensates	20
4.7. Electrical Connections	20
4.8. Electrical Diagram	21
5. CONTROL and PROGRAMMING	22
5.1. Control Panel.....	22
5.2. Keys (Functions).....	22
5.3. Display.....	23
5.3.1. Interface	23
5.3.2. Symbols	23
5.3.3. Symbols with Equipment Running.....	24
5.4. Start-up of the System	25
5.5. Operating Modes	25
5.5.1.  ECO Mode	26
5.5.2.  AUTO Mode	26
5.5.3.  BOOST Mode	26
5.5.4. LAT Mode	26
5.5.5.  TCC Mode.....	27
5.5.6. Chrono scheduling of the heat pump	28
5.6. Extra Modes	34

5.6.1. DISINFECT 34

5.6.2. VACATION Mode 34

5.7. Menu.....34

5.8. Changing Mode.....34

5.9. Number of Showers Available35

5.10. Consultation of probe temperatures (S1, S2, S3).....35

6. CHECKING GOOD RUNNING CONDITION..... 35

7. PARAMETERS DESCRIPTION 36

8. ERRORS 39

9. PROBE CHART..... 40

10. TROUBLESHOOTING 41

11. SYSTEM MAINTENANCE..... 43

11.1. General Inspection.....43

11.2. Empty the Water Storage43

11.3. Filter of Reduction Valve.....43



11.4. Condensate circuit43

11.5. Cleaning Air Circuit.....44

11.6. Safety Thermostat.....44

1. INTRO

1.1. Symbols

	<p>Every process that the supplier believes to be conducive to harmful danger and/or material damage will be signalled with a danger sign.</p> <p>To better characterize the danger, the symbol will be followed by one of these words:</p> <ul style="list-style-type: none"> • DANGER: when there is the possibility of harm to the operator and/or people in the vicinity of the equipment • WARNING: when there is the possibility of material damage to the equipment and/or attached materials.
	<p>All the information that the supplier believes to be an asset for better performance and preservation of the equipment, will be signalled together with the information sign.</p>

1.2. Safety Information

 WARNING/DANGER	
<ul style="list-style-type: none"> • The electrical installation of the equipment must comply with the national regulations for electrical installations in effect. • The equipment can only work if the water heater is filled with water and properly purged; • The electrical supply is 220 – 240 V/50 Hz or 60Hz* (equipment version only designed on specific request); • The equipment must be connected to an electrical outlet with earth contact; • If the power supply cable is damaged, it must be replaced by the manufacturer, by its customer service, or by staff with similar training in order to avoid any danger. • Children must not play with the device. • Cleaning and maintenance must not be carried out by children without supervision. • According to standard EN60335-2-40: This device can be utilized by children of 8 years old or more and by people with limited physical, sensorial or mental capabilities or with lack of experience and knowledge if they are being watched or have receive instructions regarding the use of this device in a safe manner and if they understood the risks involved. • According to standard EN60335-2-21: This device can be utilized by children of 3 years old or more and by people with limited physical, sensorial or mental capabilities or with lack of experience and knowledge if they are being watched or have receive instructions regarding the use of this device in a safe manner and if they understood the risks involved. The children of ages between 3 and 8 can only operate the tap connected to the device • According to standard EN6335-2-40 + IEC60335-2-21: This device can be utilized by children and people with limited physical, sensorial or mental capabilities or with lack of experience and knowledge if they are being watched or have receive instructions regarding the use of this device in a safe manner and if they understood the risks involved. • The operating principle of this equipment is directly linked to high temperatures and pressures, so all processes that involve contact with the equipment must be prepared with care to avoid risks of burns and material projection. • The heating of other fluids than drinking water is not allowed. 	

1.3. Information



INFORMATION

Installation

- The installation of the equipment must be carried out by staff with suitable training and qualified for this purpose.
- The device **must not be** installed:
 - outdoors;
 - in places with corrosive environment;
 - in places with a risk of temperatures below 5°C;
 - in places that present a risk of impact, shock or explosion.
- The equipment must be installed in a dry place, protected from the weather;
- Keeping the equipment packed until the place and time of installation.
- Ensure that all hydraulic connections are properly watertight before powering the equipment electrically.
- The discharge pipe connected to the pressure limiting device must be installed in a non-freezing environment and continuously directed downwards.
- The discharge tube of the pressure limiting device must be kept open to the atmosphere.

Maintenance

- The user is responsible for the safety and environmental compatibility of the installation and/or maintenance.
- Maintenance/repair should only be carried out by a brand assistance service, with the exception of general and continuous cleaning operations, which can/must be carried out by the user himself. Repairs carried out incorrectly can create risks for the user and cause the product to malfunction.
- The supplier recommends that at least an annual inspection of the equipment be carried out by a qualified technician.
- Always switch off the electrical supply to the device before carrying out any maintenance work.
- Cleaning and maintenance must not be done by children without supervision.
- Only use original replacement parts.
- The safety valve must be operated regularly to remove impurities and check that it is not blocked.
- To drain the water from the water heater, close the supply valve and open the drain valve.
- Fuses:
 - Compressor 10A;
 - General 10A.

*** Pressure Reducing Valves**

- Pressures admitted upstream of the pressure reducing valve:
 - Maximum pressure allowed 1.2 Mpa;
 - Minimum pressure allowed 0.1 MPa;
- Pressure downstream of the pressure reducing valve:
 - Factory set to 0.3 MPa;

*** Safety Group**

The safety group allows the system to be protected in the event of anomalies in the supply of cold water, hot water return, emptying of the water heater and high pressures. The valve is calibrated to operate at 0.7 MPa.

Safety thermostat

The safety thermostat is disarmed when the temperature of the water of the tank rises above normal working temperatures and can be rearmed after the cause of the disarm is uncovered.

Refrigerant

- Handle and recycle refrigerant gas, if necessary, in compliance with environmental laws. It cannot be released into the environment!
- The refrigerant gas is R134a, free of CFCs, non-flammable and without harmful effects on the ozone layer.
- Before carrying out any intervention on the components of the refrigerant circuit, evacuate/recover the refrigerant gas in order to carry out the operations safely.
- In maintenance, it must be taken into account that fluorinated greenhouse gas HFC-134a is used, covered by the Kyoto protocol GWP=1300.
- All gas handling must be carried out by a qualified technician.

In operation

- Water pressure:
 - Minimum 0,1 MPa;
 - Maximum 0,7 MPa;
- Water temperature:
 - Minimum 5 °C;
 - Maximum 65 °C;

Information to give to the customer

- The installer must inform the customer about the operation of the appliance, instruct him on its handling, and the customer's rights and duties.
- Communicate to the customer the fact that the alteration or maintenance of the device must only be carried out by specialized and accredited personnel.

(*)

Components not supplied with the equipment.
We strongly recommend its installation.



To request additional information, contact us via the email address energie@energie.pt or via our website www.energie.pt.

2. SPECIFICATIONS

2.1. Components

The **AquaPura Monobloc** package contains:

- Hot water storage tank with electric heater, in stainless steel, with or without an inner coil to be used with a thermal solar boosting system, boiler, etc.

Dimensions:

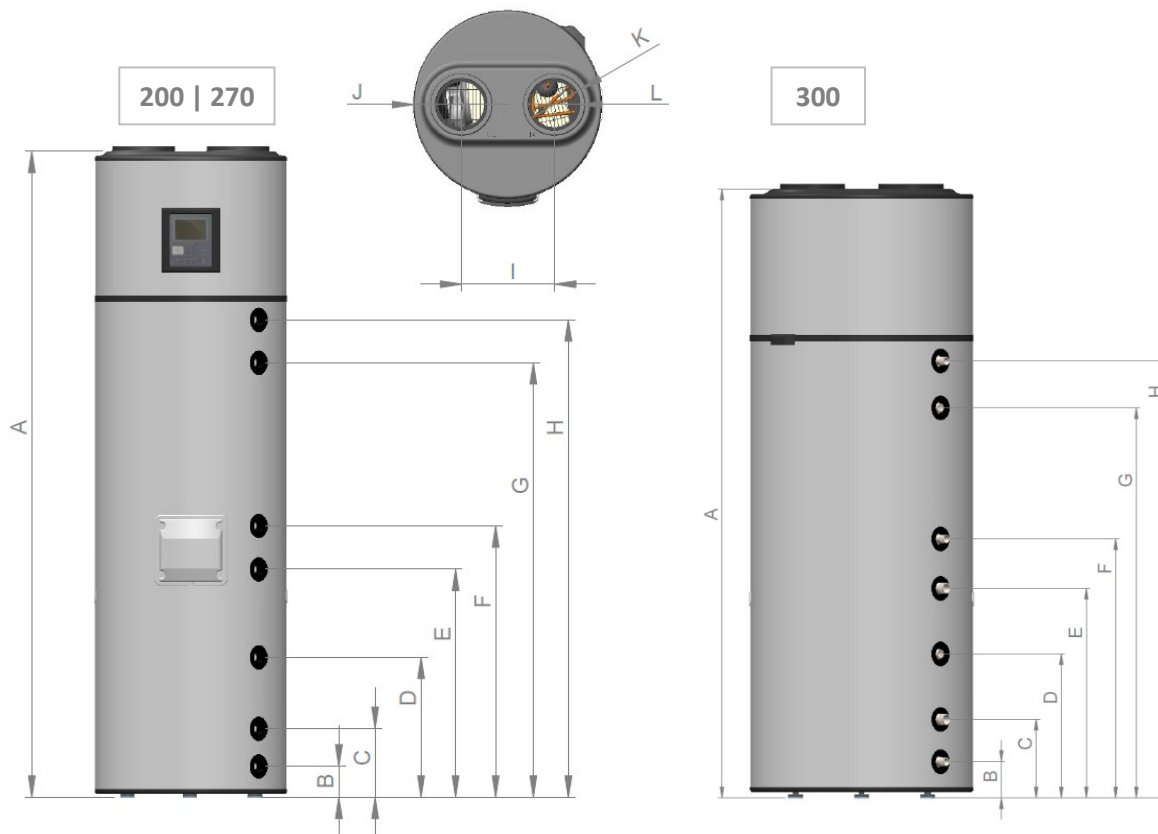

	Ø Inch.	200 I/IX mm	270 I/IX mm	300 I/IX mm	Description -
A	-	1695	1970	1860	-
B	G ¾" M	131	131	107	Cold Water
C	G 1" M	231	231	236	Support Coil
D	-	435	435	436	Instrumentation
E	G 1" M	690	690	636	Support Coil
F	G ½" F	-	840	855	Recirculation
G	G ½" F	905	1205	1065	PT Valve
H	G ¾" M	1030	1325	1190	Hot Water
I	-	Ø 580	Ø 580	Ø 650	-
J	-	286	286	286	-
K	-	Ø 190	Ø 190	Ø 190	-
L	-	Ø 160	Ø 160	Ø 160	-

500

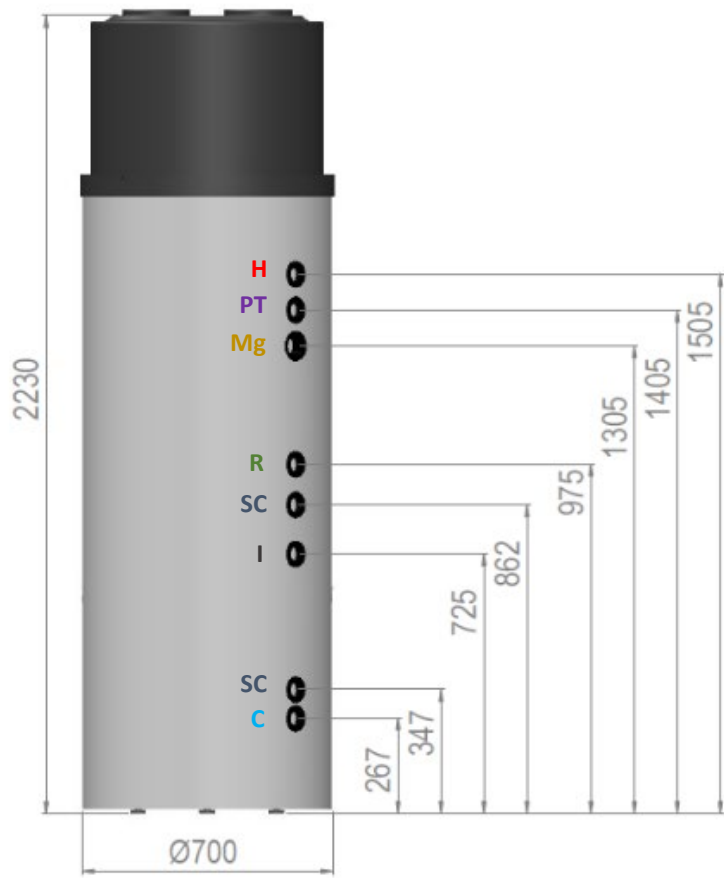
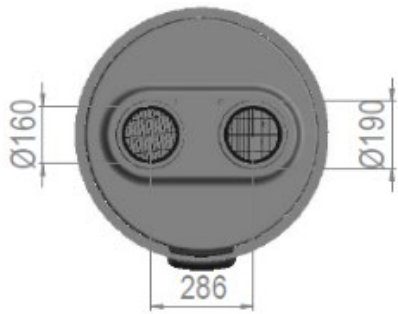

- H** Hot Water
- PT** PT Valve
- Mg** Magnesium Anode
- R** Recirculation
- I** Instrumentation
- SC** Support Coil
- C** Cold Water

- A cooling system, at the top, responsible for transferring heat from ambient air to sanitary water;

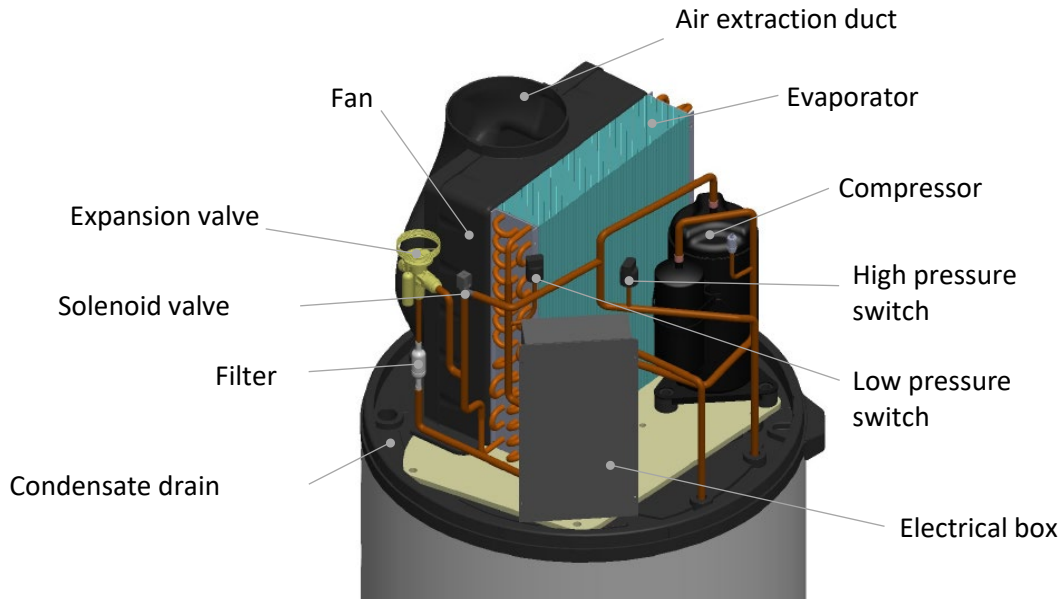

2.2. Running Principle

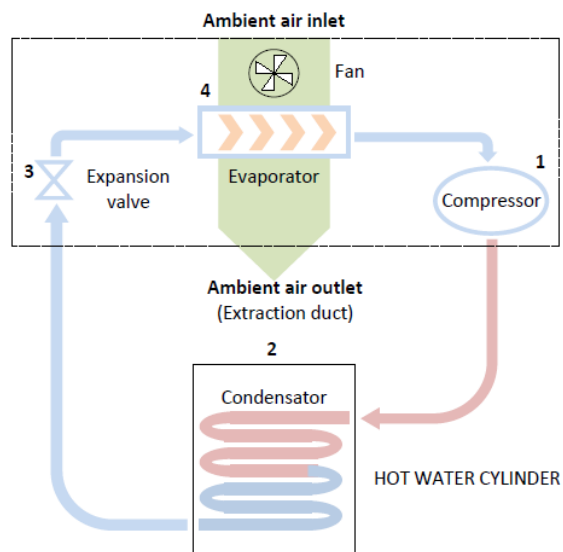

1. The cooling fluid (R134a) is compressed in the high efficient compressor, raising its pressure and temperature;
2. In the condenser (not in direct contact with the water), the heat energy in the cooling fluid is transmitted to the water in the water storage heater;
3. The condensate fluid (high pressure) runs from the expansion valve which is responsible for easing the its pressure;
4. The fluid absorbs heat energy from the environment by flowing through the evaporator with the help of a fan;



The R134a is a HFC fluid, thus not harmful to the ozone layer. It has great chemical and thermal stability, low toxicity, non-inflammable, and is compatible with most materials.

2.3. Technical Data

	Unit	200i	270i	300i	200ix	270ix	300ix	500ix
Type of Equipment	-	Air/Water Heat Pump for DHW						
DHW Capacity	L	200	270	300	195	265	295	460
Empty Weight	Kg	60	67	75	62	75	78	125
Dimensions (ø/height)	-	580/1695	580/1970	650/1860	580/1695	580/1970	650/1860	700/2230
Storage Water Heater Material	-	Stainless Steel						
Insulation	-	High-density polyurethane 50mm						
Max Running Temperature	°C	80						
Max Working Pressure	bar	7						
Test Pressure	bar	10						
Heat Loss	kWh/24h	0,99	1,01	1,17	0,99	1,01	1,17	1,85
Coil Heat Exchanger (ø / length)	m	NA			0,025 / 10			0,025 / 21
Coil Power1	kW	NA			a) 20 b) 12			a)47 b)28
Protection Index	-	IPX1						
Power Supply	-	220-240 Vac / monophasic / 50 Hz						
Absorbed Power (med / max)	W	400/700						600/950
Absorbed Power Electrical Support	W	1500						2000
Thermal Power Supplied BC	W	1800						3000
Fan Power	W	65						
Max Running Current	A	3,2 + 6,8 (electrical heater)						4,3+9 (electrical heater)
Max DHW Temperature (BC)	°C	60						
Max DHW Temperature (Backup)	°C	70						
Refrigerant	-/kg	R 134a / 1,2						
Load Profile	-	L	XL	XL	L	XL	XL	XXL
COP ²⁾	-	3,72	3,91	3,84	3,72	3,91	3,84	3,61
Heating Time ²⁾	(hh:mm)	04:36	05:57	06:29	04:36	05:57	06:29	06:48
Amount of Useful Water 40°C ²⁾	L	251	323	362	245	317	355	591
Energy Efficiency Class ²⁾	-	A++	A++	A++	A++	A++	A++	A+
Energy Efficiency ²⁾	%	154	161	160	154	161	160	150
Annual Electricity Consumption ²⁾	kWh/ano	664	1041	1049	664	1041	1049	1439
COP ³⁾	-	3,09	3,32	3,1	3,09	3,32	3,10	3,41
Heating Time ³⁾	(hh:mm)	05:52	06:52	08:58	05:52	06:52	08:58	09:45
Amount of Useful Water 40°C ³⁾	L	251	323	362	245	317	355	591
Energy Efficiency Class ³⁾	-	A+	A+	A+	A+	A+	A+	A+
Energy Efficiency ³⁾	%	128	136	127	128	136	127	142
Annual Electricity Consumption ³⁾	kWh/ano	801	1230	1319	801	1230	1319	1522
Ambient Temperature Limits	°C	-5/40						
Sound Power Level Indoor ⁴⁾	dB(A)	51						
Sound Pressure at 2m	dB(A)	36						
Air Flow	m ³ /h	450						
Static Pressure Fan	Pa	80						
Max Ducts Length	m	40						

1) a) Primary circuit (Tin =90 °C; Tout =80 °C); Production DHW (Tin=10 °C; Tout=60 °C)

b) Primary circuit (Tin =70 °C; Tout =60 °C); Production DHW (Tin=10 °C; Tout=60 °C)

2) A14/W10-54, according EN16147 and Delegated Regulation No. 812/2013

3) A7/W10-54, according EN16147 and Delegated Regulation No. 812/2013

4) According with EN12102

3. TRANSPORT

 WARNING	<p>The equipment must be carried in an upright position. The equipment must be raised and lowered with extreme care, to avoid impact that could damage the material. Make sure the belts and/or transportation straps do not damage the material. Always use suitable means to transport the material (pallet lift, forklift, etc.)</p>
-----------------------------------------------------------------------------------------------------	--------------------------------------------------------------------------------------------------------------------------------------------------------------------------------------------------------------------------------------------------------------------------------------------------------------------------------------------------------------------------------------------------------

Correct transport position:

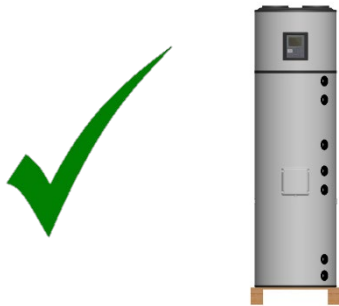

Incorrect transport position:

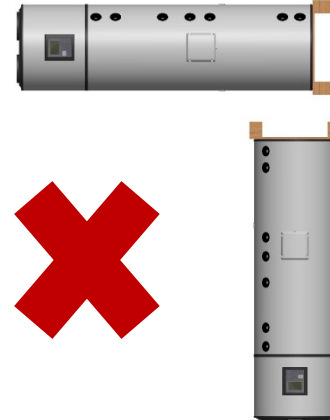





 WARNING	<p>During the transport and installation phase, do not take the equipment by the upper part.</p>
------------------------------------------------------------------------------------------------------	--------------------------------------------------------------------------------------------------

The transport and handling of the equipment at the installation local must be carried out by two people using the strap provided, which must be placed under the equipment.



The equipment must be transported in its original package to the place of installation.
 The packages contain the following information symbols:

	Fragile, handle with extreme caution		Keep the package dry
	Make sure the arrows are always up		Do not stack packages

4. INSTALLATION

4.1. Safety and Control Devices

4.1.1. High/Low Pressure Switch

In case of running outside the range of pressures recommended and defined by the supplier, the equipment will switch off and indicate error in the electronic panel.

4.1.2. Safety Thermostat

The safety thermostat is set by the supplier to ensure that the water temperature in the storage water tank with electric heater does not exceed the maximum value. If the temperature exceeds this value, the thermostat switches off the backup electrical heater. The rearm can be done manually by the client or a qualified technician, after uncovering the reasons for the disarm.

4.1.3. Temperature Probe

The purpose of the temperature probe is to measure the temperature values of water in the storage water with electric heater in order to control the system.

4.1.4. Protection Against Corrosion (If Applicable)

Besides being resistant to corrosion (stainless steel), the storage water heater has in addition a magnesium anode that should be checked periodically according to information by the installer.

4.1.5. Expansion Vessel*

The expansion vessel is a device whose purpose is to compensate for the increase in water volume due to temperature rise.



The placement of this device is a recommended procedure for a correct installation of the equipment.
Installation of this device is the responsibility of the installer.
As a general rule, it is installed in the cold water pipe.

4.1.6. Safety Group*

The safety device allows the system to be protected against anomaly situations: cold water supply, hot water flowing back, emptying of the storage water heater and high pressure. The valve is calibrated to activate at 0.7 MPa).

To drain the water in the storage water tank, you should close the supply valve and open the discharge valve.

The safety valve discharge pipe must be open into the atmosphere, because the valve may drip water or even discharge water.

The safety valve must be opened regularly to remove impurities and check that it is not blocked. The discharge pipe must be installed in a vertical position. The discharge pipe must be installed upright away from a cold environment.



Installing this device is recommended for the proper installation of the equipment.
Installing this device is the responsibility of the installer.
As a general rule it is installed in the cold water pipe.

4.1.7. Pressure Reducing Valve*

The pressure reducing valve must always be installed upstream from the safety device, and ready to activate in situations when the pressure in the circuit exceeds 3 bar (0.3MPa). This valve comes with a pressure gauge.

***Parts not supplied by the manufacturer. They must be installed by the installer.**

4.2. Drain pan

The equipment should not be installed over an area where drains from the tank or its connections could cause damage in the adjacent area or on the lower floors of the structure. For the aforementioned reasons, it is recommended to place a drain pan under the equipment.

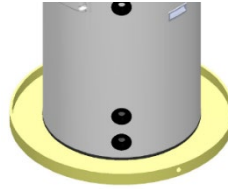

It is important that the pan has a flow channel with a minimum diameter of 3/4".

4.3. Positioning

When placing the equipment in its position, bear in mind possible future interventions. Make sure that there is at least the following free space (in mm) around the equipment:

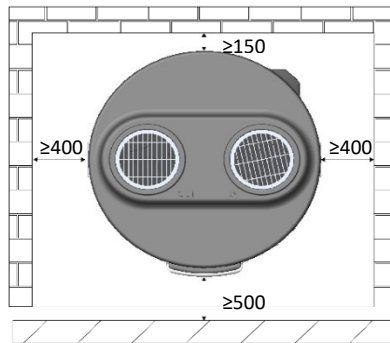

Adjust the levelling feet of the equipment. An inclination angle of up to 1° forwards or tilting backwards is acceptable.

 WARNING	If equipment tilts more than 1° forwards, this will cause condensates to deposit in the tank.
--------------------	-----------------------------------------------------------------------------------------------



4.4. Air Inlet/Outlet Installation



As the AquaPura Monobloc absorbs heat during its operation, the air flow (inlet/outlet) is cooled down and must be directed to unheated areas or to the outside. The equipment will cool the room where it is placed and so if it is installed in heated rooms, the air flow must be directed to other rooms and/or the outside.

4.4.1. Installation without Ducts

The **AquaPura Monobloc** equipment must be installed in a place that is not too heated, and may be used for dehumidifying and cooling these rooms (e.g., laundries, cellars, etc). Distance between the top of the unit and the ceiling must be no less than 600mm.

If the distance between the unit and the ceiling is less than 600mm, two elbow-type joints must be installed as shown in the following picture.



4.4.2. Installation with Ducts

The AquaPura Monobloc is prepared to install ducts with diameter of 160 mm and 190 mm, in its air intake and extraction zones:

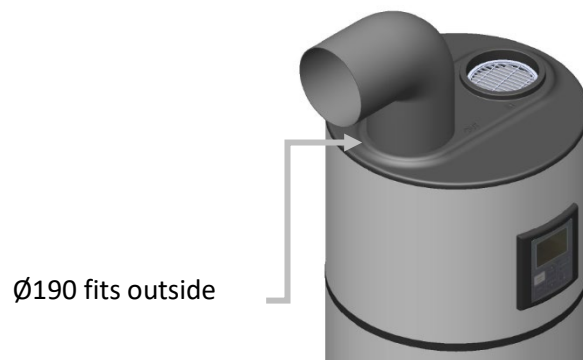
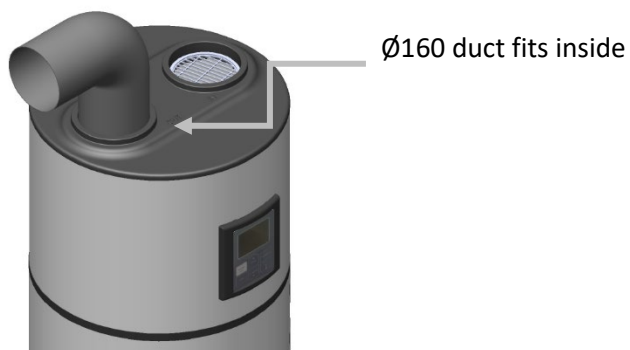

		Max Length Ducts	
		Ø160	Ø190
Rigid duct ¹⁾	m	24	40
Flexible duct ¹⁾	m	12	20

1) Considering 90° curves and louvers at the air inlet and outlet of the equipment.

If ducts are used, directing the air flow to areas that do not require heating, there are some options:

Using Outside Air

If outside air is used, the unit may be placed either in a heated room or in an unheated room.

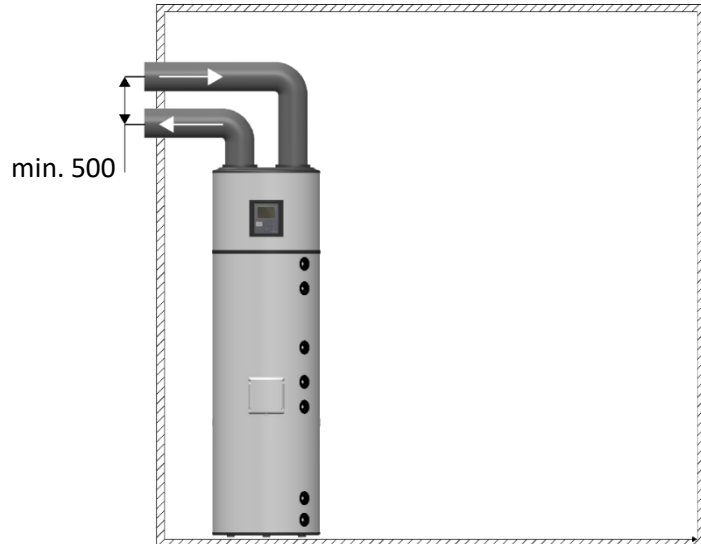

Using Ambient Air

The monobloc unit may also be placed in a heated room, but the air flow must be directed to an unheated room. Bear in mind that because of air flow, cooling the unheated room can affect the adjacent heated rooms.

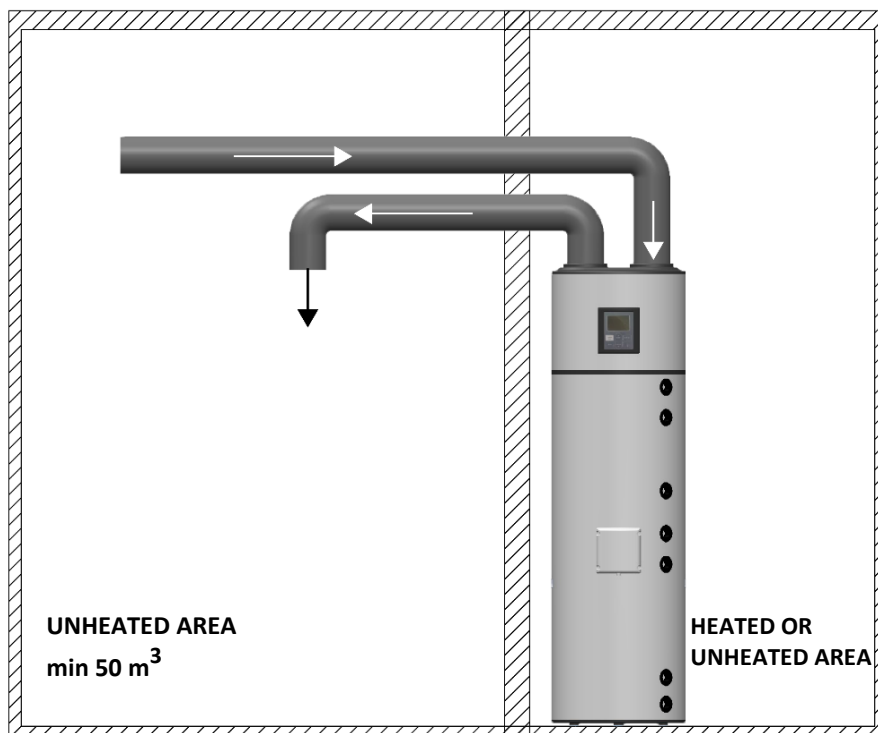

Using Ambient and Outside Air

A branched duct can be used to inflate air into the equipment. So you can get hot air in the summer, from the outside, and hot air in the winter from an unheated room.

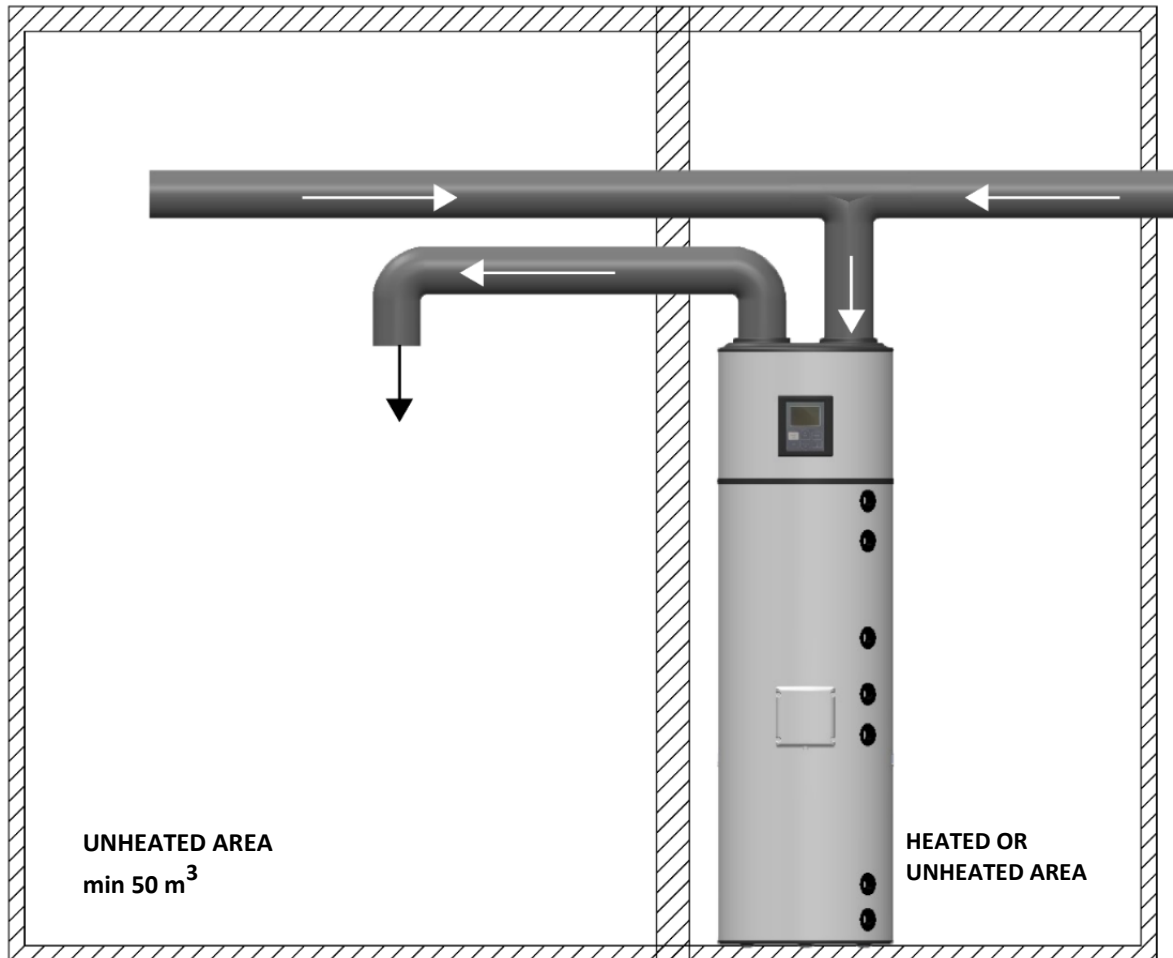

Ducts used to direct the airflow are not included in the equipment, and it is up to the installer to install them, if necessary, to comply with the manufacturer's recommendations.

Diameter of pipes must be of 160 mm or 190mm.

Pipes must not exceed 40 m in length.

4.5. Hydraulic Installation

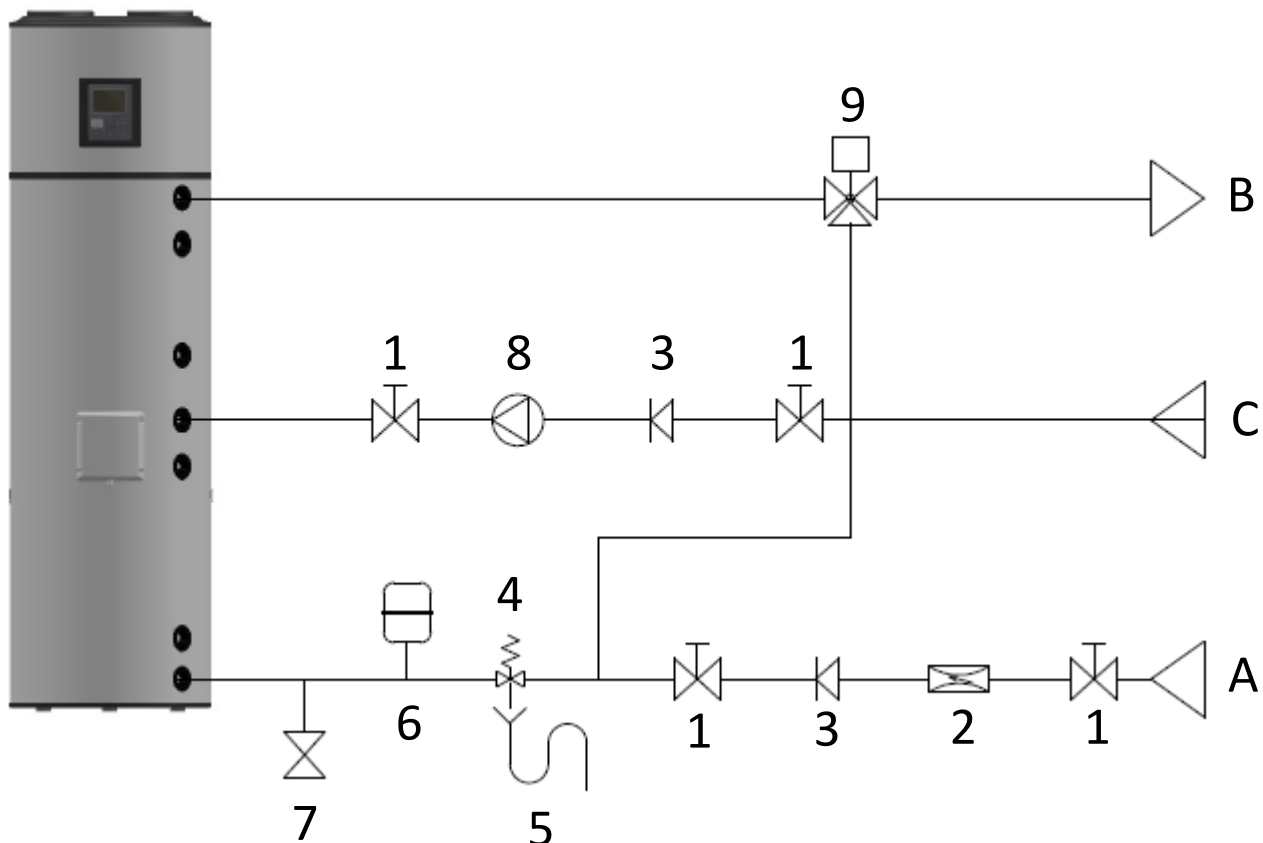

Caption

- | | |
|---------------------------------------------|-----------------------------|
| 1 Shut Off Valve | 7 Drain Valve |
| 2 Pressure Reducing Valve (3 bar / 0,3 MPa) | 8 Circulating Pump |
| 3 Non-return Valve | 9 Thermostatic Mixing Valve |
| 4 Safety group (7 bar / 0,7 MPa) | A Cold Water Inlet |
| 5 Drainage Siphon | B Hot Water Outlet |
| 6 Expansion Vessel | C Recirculation |





It is necessary to install a safety device at the cold water inlet of the appliance. The safety device must be in compliance with the standard EN 1487:2002, maximum pressure 7 bar (0.7 MPa) Water must not be stopped from flowing from the safety device to the deposit by any sort of accessory.

The safety device must be connected with piping whose diameter is not less than the cold water inlet coupling. The discharge must be connected to a sewage siphon or, if this is not possible, elevated to a distance of at least 20 mm from the pavement to allow visual inspection;

To prevent high pressure from main water supply, install a pressure reduction valve set to 3 bar (0.3 MPa).



The Manufacture is not responsible for damage related to not following these recommendations/ warnings.

WARNING / DANGER

The water you use may contain impurities and/or substances damaging to the system and even harmful to your health. Make sure you use water with quality fitting for home consumption. The following table indicates some parameters that, when exceeded, must be chemically treated.

Hardness (°dH)	pH	Treatment
3,0 - 20,0	6,5 - 8,5	No
3,0 - 20,0	<6,5 - >8,5	Yes
<3,0 - >20,0	-	Yes

4.6. Condensates

During operation, condensation may occur. These condensates are collected in the drip tray and drained through a hole at the back of the tray. The installer must connect the condensate hose supplied by the manufacturer and direct the condensates to the drainage system or drainage siphon.





WARNING

The condensate hose must not be bent/pressed and must be placed where it best suits the proper flow of condensates.

4.7. Electrical Connections

The heat pump must be plugged to the power supply only after filling the storage water tank. It comes with a mains cable, to be connected to an earthed monophase voltage (230VAC/50HZ). The connections must comply with the standards of installation in effect in the territory or country where the monobloc heat pump has been installed.

The installation includes:

- Bipolar circuit-breaker with connection cable with section equal to or exceeding 2.5 mm
- Protection differential circuit breaker of 30 mA

If the power supply cable is damaged, it must be replaced by the manufacturer, by its customer service, or by staff with similar training.

4.8. Electrical Diagram

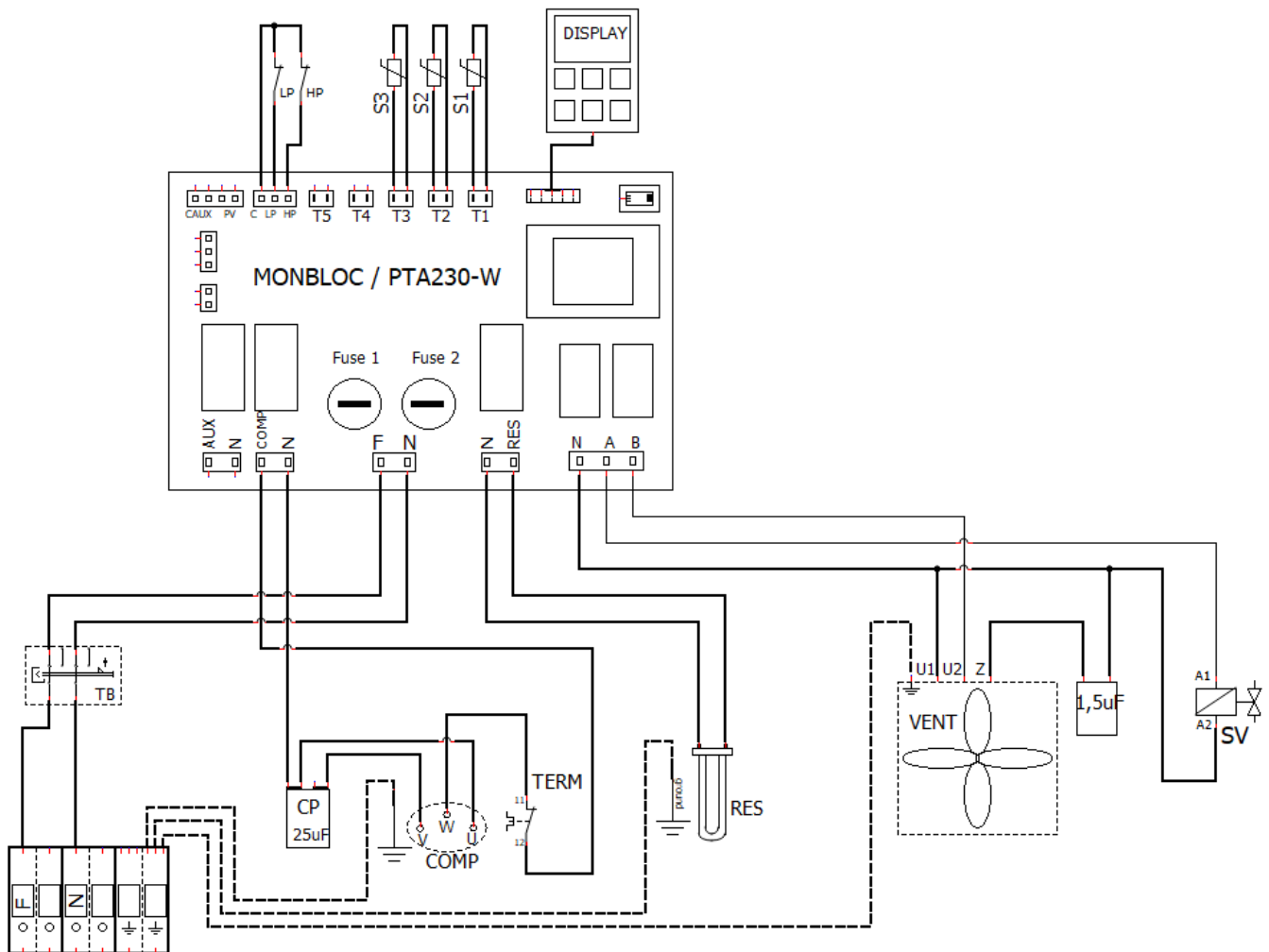

CAPTION

- | | | | |
|---------------|-------------------------------|---------------|-------------------------------|
| RES | Electrical backup heater | Fuse 2 | Fuse 10A type F(fast cut-off) |
| S1 | Water temperature probe | ⊥ | Ground |
| S2 | Ambient temperature probe | HP | High pressure switch |
| S3 | Evaporator temperature probe | LP | Low pressure switch |
| VENT | Fan | COMP | Compressor |
| SV | Solenoid valve | TB | Safety thermostat |
| N | Neutral | TERM | Compressor thermal |
| F | Phase | T4 | Solar thermal probe |
| Fuse 1 | Fuse 10A type F(fast cut-off) | | |



5. CONTROL and PROGRAMMING

5.1. Control Panel

The control panel of the AquaPura Monobloc is simple and intuitive. It enables the configuration of several operating parameters according to the operating mode selected by the user.

It comprises six command keys (ON / OFF / CANCEL, MENU, COMP ▲, E-HEATER ▼, DISINFECT and OK / LOCK) that enable checking the running of the equipment, consult and change parameters.

5.2. Keys (Functions)

Key	Function	Description
ON/OFF CANCEL	(ON/OFF) Switch on/off	Switch on and off controller.
	(CANCEL) Exit	ESC function to exit menu, submenu or cancel a function
	(OK) Confirmation	Confirm parameters within menus or submenus
	(LOCK) Lock / Unlock	Lock or unlock keyboard
MENU	MENU	Enter menu
COMP	ON/OFF Compressor	Pressing the key allows you to switch on and off the Compressor
E-HEATER	ON/OFF Electrical heater	Pressing the key allows you to switch on and off the electrical heater
	Change Values	It allows you to alter value of parameter (Inside Menu)
	Navigate through Menus/Submenus	Function to run through menus and submenus (inside Menu)
DISINFECT	(DISINFECT) Anti-legionella	Press this key and the system will automatically create a thermal shock in the water to neutralize bacteria (Legionella)

5.3. Display

5.3.1. Interface

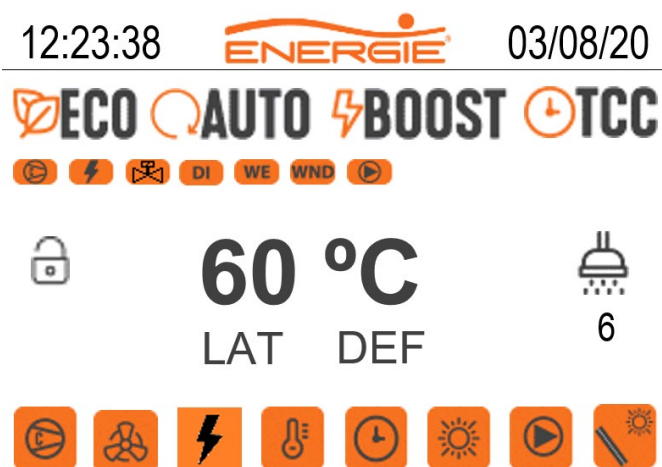

5.3.2. Symbols

LED	Description
ECO	Equipment in ECO operating mode
AUTO	Equipment in AUTO operating mode
BOOST	Equipment in BOOST operating mode
TCC	Timer clock control
LAT	Low Ambient Temperature protection
DEF	Defrost
	Compressor
	Fan
	Electrical heater
	Disinfect
	Chrono function
	Vacation mode
	Recirculation pump function
	Solar function
°C	Water temperature
	Number of baths available
	Unlocked keyboard
	Locked keyboard

5.3.3. Symbols with Equipment Running

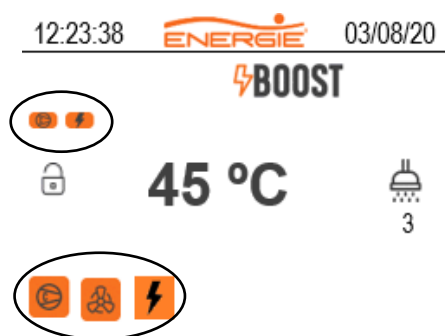

Symbol	Description
	Compressor ACTIVATED
	Compressor RUNNING
	Electrical heater ACTIVATED
	Electrical heater RUNNING
TA 	Electrical heater ACTIVATED when S1 < P08 and/or P07 > Temperature S3 (Auto Mode)
TC 	Electrical heater ACTIVATED when compressor continuous running time exceeds T05 (Auto mode)
MA 	Electrical heater ACTIVATED manually.
	Fan RUNNING
	Disinfect RUNNING
	Pressure equalization valve RUNNING
	Chrono function ACTIVATED
DI	Chrono function RUNNING everyday
WE	Chrono function RUNNING only during the week (monday to friday)
WND	Chrono function RUNNING only during the weekend (saturday and sunday)
	Vacation mode ACTIVATED
	Recirculation pump function ACTIVATED
	Recirculation pump function RUNNING
	Solar function ACTIVATED
LAT	Low Ambient Temperature protection RUNNING
DEF	Defrost RUNNING

5.4. Start-up of the System

Before starting, check whether the installation is set up according to the recommendations and that everything is in conformity, then you may plug your equipment to the power supply.

After switching on your equipment by plugging it into the power supply, you should wait a few seconds until the controller begins to work. Then you may start your equipment following these instructions:

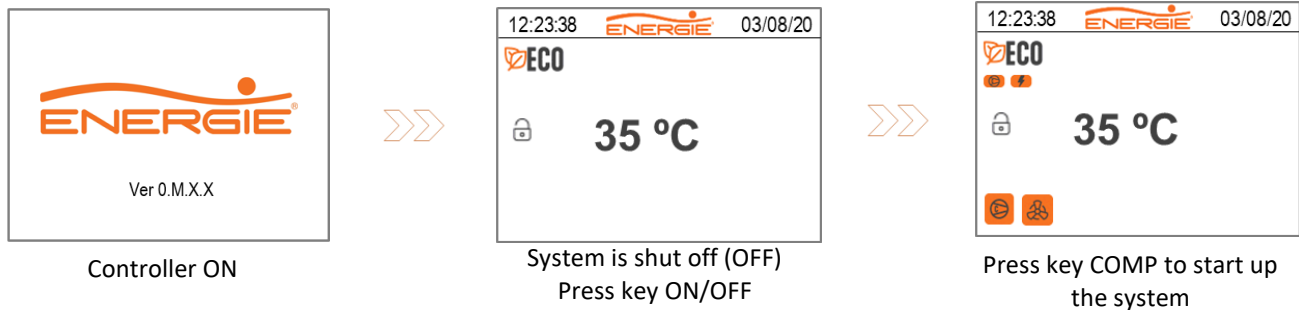

Note 1: The LED on the display indicates the status of your equipment. When is blinking means that your equipment don't have any order to work, if the LED is ON and no blinking, your system is working with the order that was given.

Note 2: To restart the appliance, switch it off and switch on again using the key ON/OFF.

5.5. Operating Modes

The AquaPura Monobloc is programmed to work in 3 main running modes: **ECO**, **AUTO**, **BOOST**. The equipment can also work in **LAT** (protection of the compressor) and **TCC** (alternative energy source).

Mode	Symbol (display)	Description
ECO		Normal running as Heat Pump
AUTO		Optimized management of running of Heat Pump and/or Electrical Heater (backup)
BOOST		Running of Heat Pump + Electrical Heater (backup)
LAT	LAT	Running of Electrical Heater (backup)+ Fan
TCC		Running of Heat Pump + Electrical Heater (backup)

5.5.1. ECO Mode

In ECO operating mode, the equipment runs only as a Heat Pump to heat the water in the storage water tank. Thus, we could generate a greater efficiency, and savings for the user. Every time the user feels it necessary, may switch on the support electrical heater, using this mode, manually pressing the key (E-HEATER). In these circumstances the equipment will automatically change operating mode to BOOST and indicates the reason of its activation (over the electrical heater). If you switch off the electrical heater manually, the equipment will begin to run again in ECO mode.

5.5.2. AUTO Mode

In AUTO operating mode, the equipment will run as a Thermodynamic System and/or electrical heater, and the operation of the electrical heater is managed in an optimized way for the purpose of keeping up the efficiency of the equipment.

The electrical heater will start every time:

- The user activates it manually (key E-Heater).
- The contact LP opens (low external temperature, lack of fluid, leak in the circuit, etc.).
- The time for running the compressor exceeds parameter T05*
- The water temperature is below P08*.

*Parameter is adjustable (ON / OFF)

5.5.3. BOOST Mode

In BOOST operating mode, the equipment runs as a Heat Pump + Electrical Heater, and the running of the electrical heater is simultaneous with the Heat Pump. This mode enables the user to obtain hot water in less time.

The user can change the operating mode when he wishes, he need only press simultaneously the keys MENU + OK/LOCK for 3 seconds and select the mode that suits his needs with the cursor.

5.5.4. LAT Mode

The LAT mode starts when the ambient temperature is too low, in order to protect the compressor. When this mode is activated, the compressor turns off and the electrical heater starts. When the ambient temperature increases, the equipment will assume the previous mode selected.

5.5.5. ☉TCC Mode

The TCC function provides the possibility of raising the water temperature when an alternative power source is available (solar photovoltaic, wind or other), increasing the efficiency of the heat pump and making the alternative power source profitable.

To this end, it is sufficient to connect a cable from the inverter to the equipment's control board. The cable connection on the control board must be made at the voltage-controlled terminals. It should be noted that this is a dry contact (no voltage), applying a voltage to this contact can cause irreversible damage to the controller.

When the voltage-controlled contact closes it triggers the TCC Function and all active heat sources (Heat Pump + Electrical heater) are adjusted to new operating parameters. The compressor assumes the P01TCC/ H01TCC parameters and the electrical heater the P02TCC/ H02TCC parameters.

Note: when the voltage-controlled contact opens the equipment assumes the previously adopted operating mode.

The PV contact can also be used to take advantage of the bi-hourly tariff. For this a timer should be connected to the PV contact, instead of the inverter.

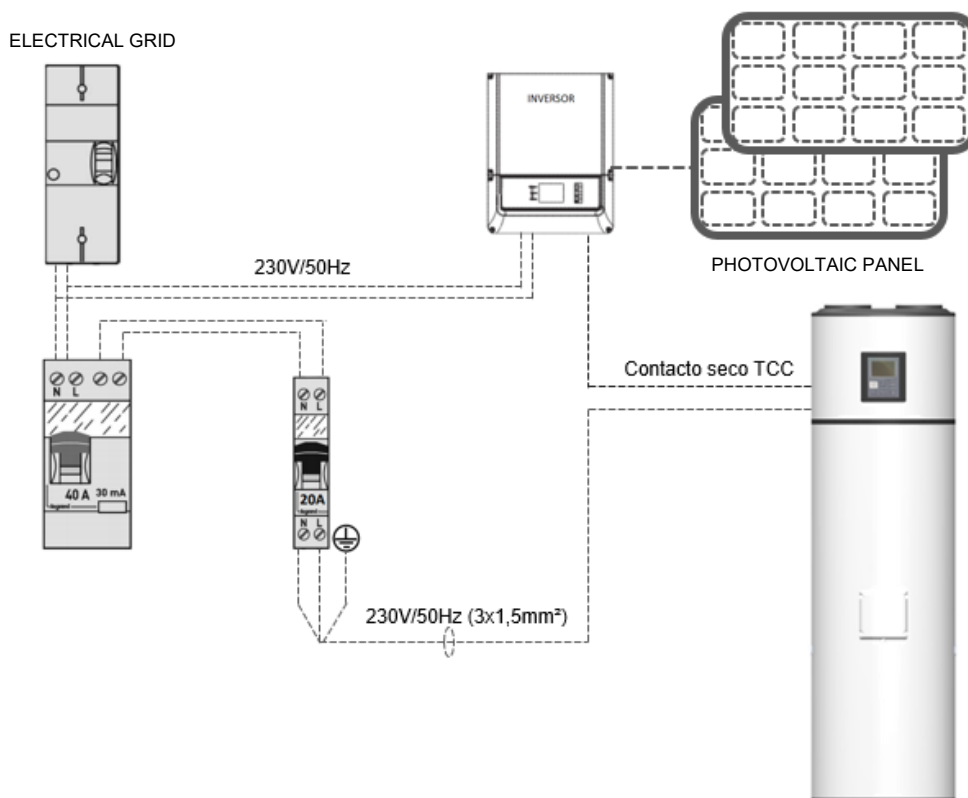
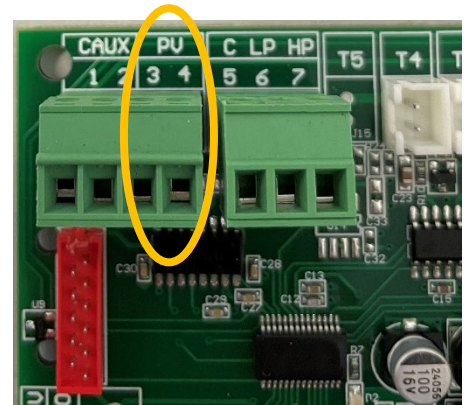

 WARNING	<p>The cable to be connected on the control card to activate the TCC mode must be a dry contact (no voltage). Applying a voltage to this contact may cause irreversible damage to the controller.</p>
-------------------------------------------------------------------------------------------------------	----------------------------------------------------------------------------------------------------------------------------------------------------------------------------------------------------------------------------

5.5.6. Chrono scheduling of the heat pump

The heat pump has an internal clock that allows the user to set two periods of operation for the control of the equipment. These periods can be distinctly defined as weekly (Monday to Friday) or weekend (Saturday and Sunday).

Once the periods of operation have been programmed, the user must then activate them, for example:

12:23:38		03/08/20
>ON/OFF Chrono		
Week		
ON	<input checked="" type="checkbox"/>	OFF <input type="checkbox"/>
Weekend		
ON	<input checked="" type="checkbox"/>	OFF <input type="checkbox"/>

Note: The programming is set for a 24-hour period, considering first of all the lowest hour in the table, for example:

12:23:38		03/08/20
> Week		
1 – Period		
ON	OFF	
10:05 hh:mm	11:40 hh:mm	
2 – Period		
ON	OFF	
21:15 hh:mm	23:00 hh:mm	

In short, the following procedures should be carried out to define the operating hours:

- 1° - Enter the menu and access the parameter "Chrono Heat Pump";
- 2° - Select, for example, a weekly schedule (Monday to Friday);
- 3° - Set the operating time for each period;
- 4° - Activate or deactivate.

5.5.7. Chrono scheduling of the recirculation pump

The heat pump has an internal clock that allows the user to set two periods of operation for the pump of recirculation. These periods can be distinctly defined as weekly (Monday to Friday) or weekend (Saturday and Sunday).

Once the periods of operation have been programmed, the user must then activate them, for example:

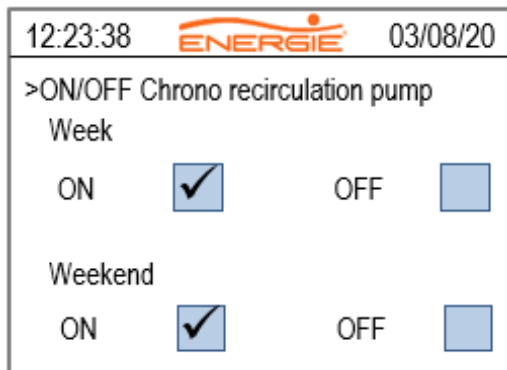

Note: The programming is set for a 24h-period, considering first of all the lowest hour of the table, for example:

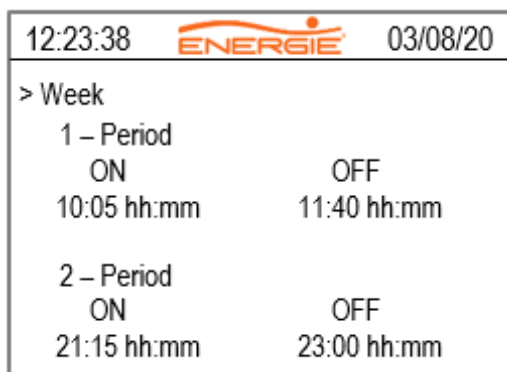

In short, to set the operating time of the pump of recirculation the following procedures must be carried out:

- 1° - Enter the menu and access the parameter "Chrono Recirculation Pump";
- 2° - Select, for example, a weekly schedule (Monday to Friday);
- 3° - Set the operating time for each period;
- 4° - Activate or deactivate.

5.5.8. Additional functions

The heat pump controller has four additional functions available. These functions allow the management/control of a solar thermal installation and pump of recirculation.

To configure these functions, it is necessary to enter the installer level of access (F11), access the submenu parameters (F08) and select parameter P12.

According to the value of the parameter set in parameter P12, the controller assumes the following functions:

Parameter P12 = 0:

Management/control of solar thermal installation and pump of recirculation is inactive.

Parameter P12 = 1:

The heat pump controller assumes the control of the solar thermal installation in parallel with the operation of the heat pump.

Depending on the temperature probe value S4 (solar collector) and the temperature probe value S1 (inside the water tank) the solar pump of recirculation "Ps" is activated.

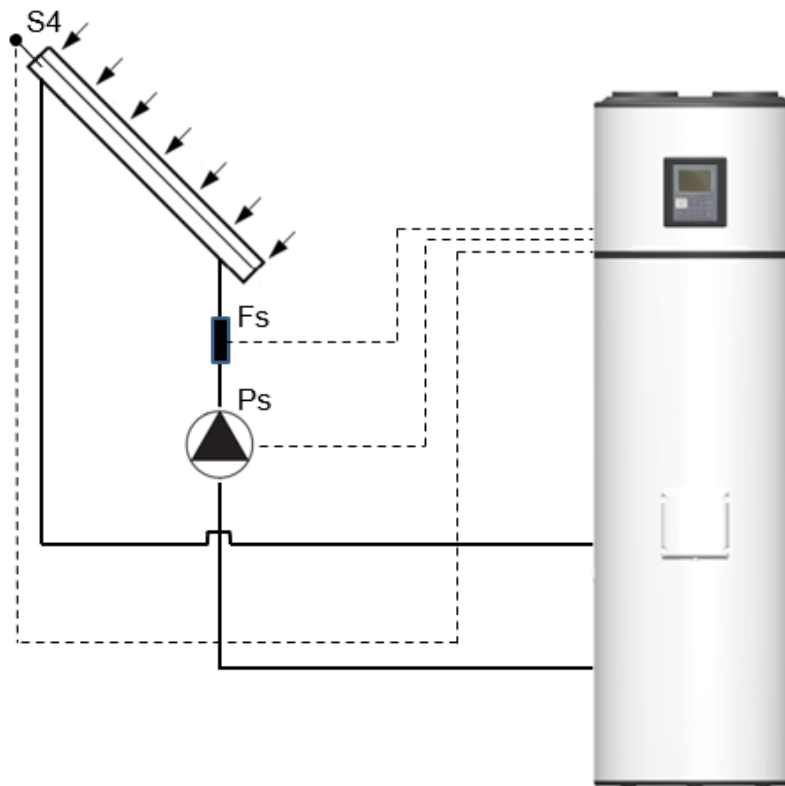

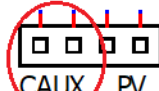
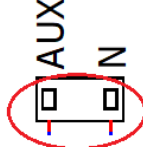
Code	Description	Connection terminals
S4	Solar collector temperature probe (NTC10KΩ@25°C)	 Terminal T4
Fs	Flow switch	 Terminal CAUX
Ps	Solar pump of recirculation	 Terminal AUX/N

Parameter P12 = 2:

In the presence of a "SC" electronic control unit to control the solar thermal installation, it is possible to put the heat pump on standby whenever there is solar production, this is, when the solar thermal installation is producing the electronic control unit activates the auxiliary contact "CAUX" and the heat pump automatically goes on standby. As soon as the auxiliary CAUX contact is inactive the heat pump automatically switches to normal operation.

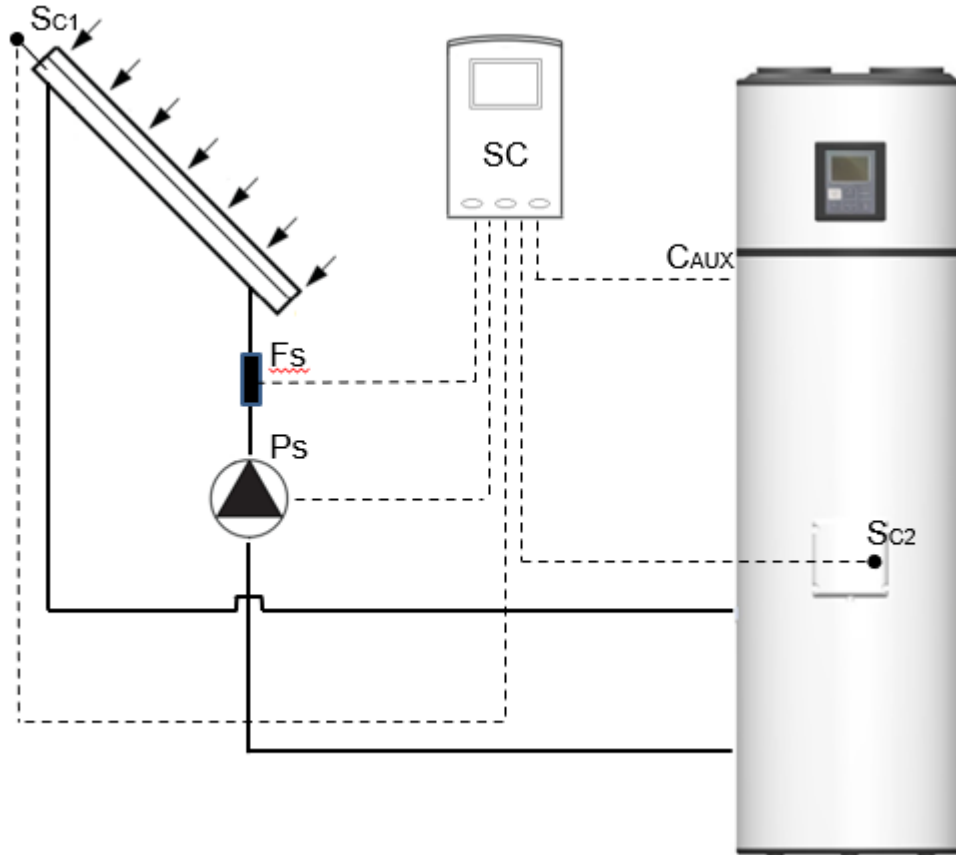

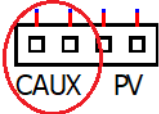
Code	Description	Connection terminals
SC	Solar electronic control unit	Connections in the solar electronic control unit
Sc1	Solar collector temperature probe	
Sc2	Storage water heater temperature probe	
Fs	Flow switch	
Ps	Solar pump of recirculation	
CAUX	Auxiliary contact for heat pump control (contact free of "dry contact" voltage). Closed CAUX contact - heat pump in standby; Open CAUX contact - Heat pump in normal operation.	 Terminal CAUX

Parameter P12 = 3:

In the presence of a "SC" electronic control unit to control the solar thermal installation, it is possible to put the heat pump on standby whenever there is solar production, this is, when the solar thermal installation is producing the electronic control unit activates the auxiliary contact "CAUX" and the heat pump automatically goes on standby. As soon as the auxiliary contact "CAUX" is inactive the heat pump automatically switches to normal operation.

Regardless of whether the heat pump is on standby or in normal operation, control of the "PR" pump of recirculation is ensured by the heat pump controller.

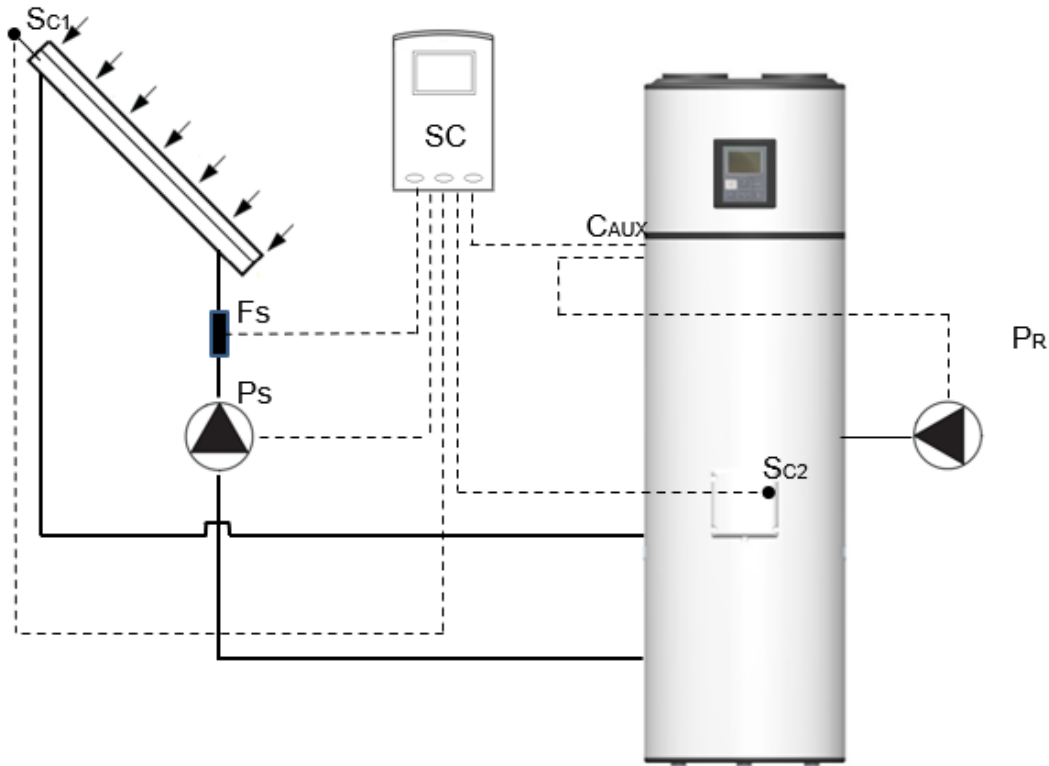

Code	Description	Connection terminals
SC	Solar electronic control unit	Connections in the solar electronic control unit
Sc1	Solar collector temperature probe	
Sc2	Storage water heater temperature probe	
Fs	Flow switch	
Ps	Solar pump of recirculation	
CAUX	Auxiliary contact for heat pump control (contact free of "dry contact" voltage). Closed CAUX contact - heat pump in standby; Open CAUX contact - Heat pump in normal operation.	 Terminal CAUX
PR	Pump of recirculation	 Terminal AUX/N

Parameter P12 = 4:

The heat pump controller assumes the control of a recirculation pump in parallel with the heat pump control.

The pump of recirculation is driven by the hourly period set by the user and the temperature in the heat accumulator.

NOTE: The pump of recirculation only comes into operation when there is a defined time period, active period, and the compressor or electrical heater is active.

PR – Recirculation Pump

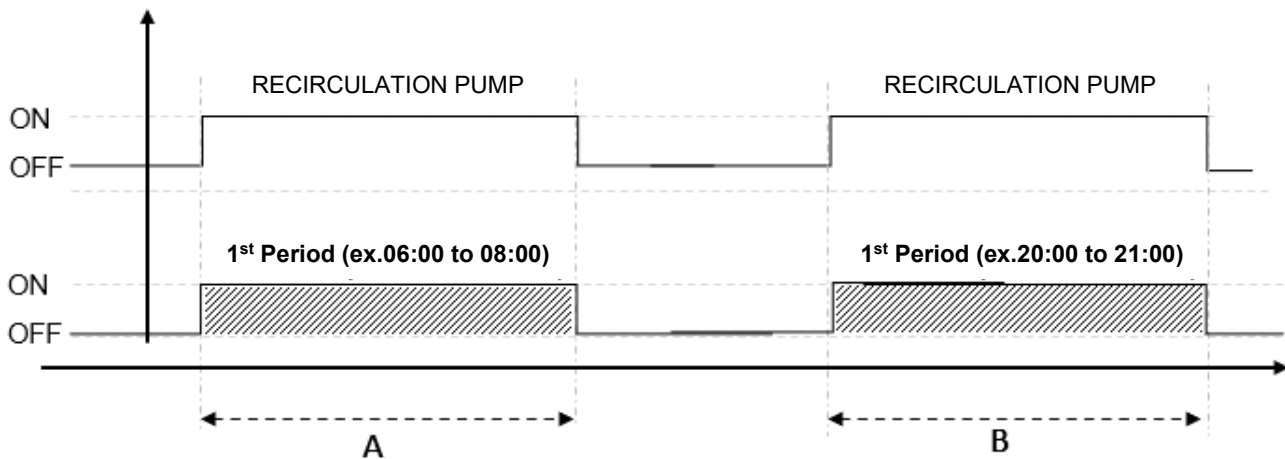
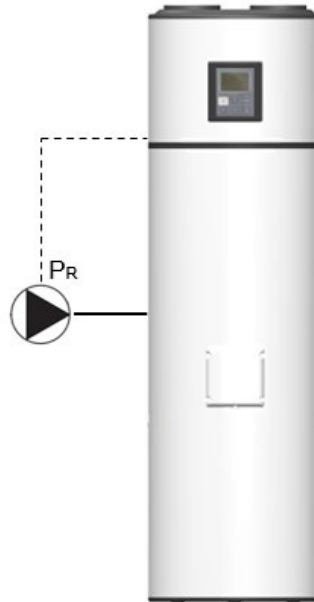

Condition	Description	Pump connection terminal
A e B	Pump of recirculation active whenever: <ul style="list-style-type: none"> • Temperature at probe S1 > P13; • Defined and active time period; • Active compressor or electrical heater. If none of these conditions are met, the pump of recirculation will not work.	Terminal AUX/N

5.6. Extra Modes

5.6.1. DISINFECT

The Monobloc electronic control features the Disinfect function, which consists of a water heating cycle up to 65 °C, for a period of time long enough to prevent the formation of germs inside the tank. The Disinfect function can be set automatically or manually. In automatic mode, the user has the possibility of setting the function every week or every month. When automatic mode is not activated, the user must activate it manually on the key Disinfect.

At the end of the function, the system returns to the operating mode that was selected at the beginning.

5.6.2. VACATION Mode

To activate the vacation function you need to access the menu and set the number of days on holiday that you wish, and your equipment will automatically enter Standby mode until the last day of holidays. On the last day, the equipment will begin the Disinfect function to eliminate any formation of germs that appeared in the storage water tank during the time you were absent.

After the holidays and once the program Disinfect is over, the equipment will resume the mode selected (ECO, AUTO or BOOST).

Note: If you set your equipment to enter Vacation mode and turn it off with the key ON/OFF, the function becomes inactive. When you return from your holidays you must remember to switch on your equipment and cancel the days of holidays introduced (Value=0). If you do not carry out this operation, your equipment will not restart until the days of holidays selected have expired.

5.7. Menu

Every time it becomes necessary to alter or set new parameters in the running of the equipment, the user must access the Menu.

To access the menu, the key MENU must be pressed for 3 seconds.

After access use the keys COMP ▲ and E-HEATER ▼, to navigate the menus and submenus. In order to confirm values / parameters press the key OK/LOCK. Press the key CANCEL to exit the menu.

5.8. Changing Mode

The equipment is set by default to work in the “ECO” operating mode. If the user wishes to alter the operating mode, he/she must follow these procedures:

Unblock the keyboard and press the key Menu.

Using keys ▲ ▼ run through menu and select F05, access submenu and select the operating mode.

Note: In order to change the operating mode, is not necessary to reinitiate the equipment.

5.9. Number of Showers Available

The user can consult the number of showers available on the home page of the graphical interface (display) by using a volume of hot water at a temperature of 40°C or more. On the initial page of the display, the parameter mentioned in this chapter will be displayed by resorting to the icon of a shower, with the number indicating the number of showers being positioned below.

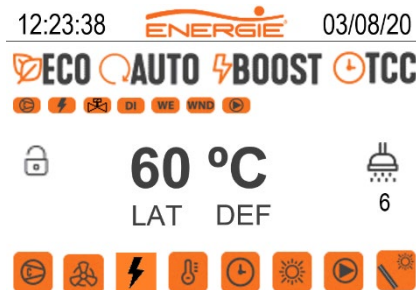

Relevant considerations:

- The illustrative set presented above will not be visible on the display whenever the water temperature inside the tank is below 38°C;
- The number of available showers is calculated considering that one shower is approximately equivalent to a consumption of 50L of domestic hot water;

5.10. Consultation of probe temperatures (S1, S2, S3)

As shown below, on the initial page of the display it is possible to consult the temperatures of the probes:

- **S1** – Water temperature probe
- **S2** – Room temperature probe
- **S3** – Evaporator temperature probe

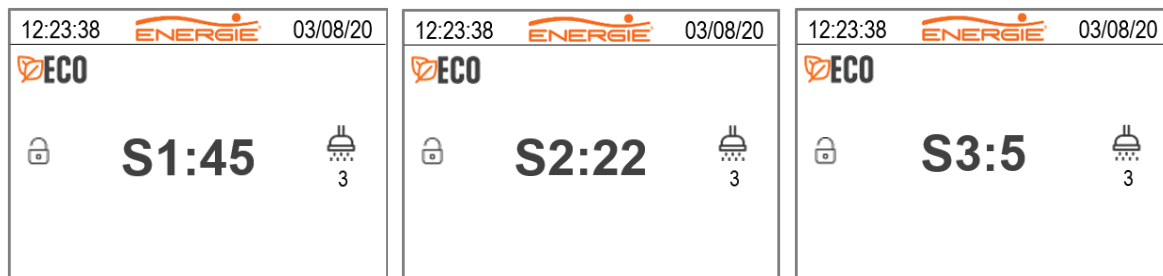

In order for the user to be able to view these parameters, it is sufficient to select the keys on the display initial page ▲ ▼.

6. CHECKING GOOD RUNNING CONDITION

To check that your equipment is working properly put it into operation and wait at least 20 to 30 minutes and then check the following conditions:

- The air temperature at the outlet of the evaporator should be 3°C to 4°C lower than the temperature of the inlet air.

7. PARAMETERS DESCRIPTION

Code	Type	Function	Min	Max	Default	Units
F01	Language	Portuguese English Français Deutsch Italiano Español	---	---	English	---
F02	Clock	Date and Time	---	---	---	---
F03	Chrono Heat Pump	Week Weekend ON/ OFF chrono	---	---	Chrono = OFF	---
F04	Chrono Recirculation Pump	Week Weekend ON/ OFF chrono	---	---	Chrono = OFF	---
F05	Mode	Eco Boost Auto	---	---	Eco	---
F06	Holidays	Number of days	1	99	0	---
F07	Disinfect	Disinfect function inactive Disinfect function active once a week (weekly) Disinfect function active once a month (monthly) Number of days	---	---	Inactive	---
F08	Parameters	P01 - Setpoint Compressor 1	10	60	52	°C
		H01 - Gradient P01	2	20	2	°C
		P02 - Setpoint Electrical heater	10	65	52	°C
		H02 - Gradient P02	1	20	3	°C
		P01 TCC Setpoint Compressor	10	60	55	°C
		H01 TCC Gradient P01 TCC	2	20	2	°C
		P02 TCC Setpoint Electrical heater	10	65	65	°C
		H02 TCC Gradient de P02 TCC	2	20	15	°C
		P03 - Setpoint start defrost cycle	-15	10	-8	°C
		P04 - Temperature finish defrost cycle	-10	20	10	°C
		P05 - Safety temperature	70	80	75	°C
		P06 - Setpoint disinfect	60	70	65	°C
		P07 - Temp. min Evaporator to activate electrical heater (AUTO mode)	-20	20	-5 ON	°C
		P08 - Temp. min water to activate electrical heater (AUTO mode)	10	40	30 ON	°C
		P09 – Air temperature to allow defrost cycle	-5	15	5	°C
		P10 – Setpoint to activate the LAT protection mode (Low ambient temperature)	-10	10	-2	°C
		H10 – Gradient P10	2	20	7	°C
		P11 – Gradient to activate the Solar Thermal Pump	2	10	5	°C
P12 – Additional Functions	0	4	0 – Inactive	***		
P13 – Minimum water temperature to activate the recirculation pump	20	50	30			
T01 (timer) – Delay time to compressor starts running	1	20	2	min		
T02 – Not used	-	-	-	-		

		T03 (timer) – Maximum defrost cycle time	1	10	5	min
		T04 – Not used	-	-	-	-
		T05 (timer) – Maximum time compressor running	6	15	12	hours
		T06 (timer) – Delay for defrost cycle	30	360	60	sec
		T07 (timer) – Delay time to compressor starts running after LP error	1	20	10	min
		T08 (timer) – Time between defrost cycle	10	120	30	min
		T09 (timer) – Delay for LAT mode starts	2	20	5	min
		T10 (timer) – Minimum time for defrost cycle	1	10	2	min
		T11 (timer) – Delay time LP alarm	1	10	1	min
		T12 (timer) – Delay time water flow alarm	5	120	10	sec
		T13 (timer) – Delay time to restart the solar thermal pump	1	10	5	min
F09	INFO	Temperature Probe 1 Temperature Probe 2 Temperature Probe 3 Temperature Probe 4 P01 Setpoint compressor H01 Gradient P01 P02 Setpoint Electrical heater H02 Gradient P02 P05 Water temperature alarm P06 Setpoint anti-legionella P10 Setpoint to LAT Mode starts H10 Gradient P10 P12 Additional Functions T01 Delay compressor starts running T05 Maximum time compressor running Next Disinfect Compressor instant consumption Electrical heater instant consumption			---	---
F10	Efficiency	Energy consumption <ul style="list-style-type: none"> • Compressor (instant W) • Electrical heater (instant W) • Compressor (daily kWh) • Electrical heater (daily kWh) • Compressor (total kWh) • Electrical heater (total kWh) Energy savings <ul style="list-style-type: none"> • Energy savings (kWh) 	---	---	---	---
F11	Levels of access	Installer	Password: 0022			---
		Manufacturer	Password: ****			---

F12	Test Outputs	COMP - Contact N.O Compressor output	---	---
		RES - Contact N.O Electrical heater output	---	---
		VE - Contact N.O Fan output	---	---
		VS - Contact N.O Solenoid valve output	---	---
		AUX - Contact N.O Auxiliary contact output (recirculation pump / Solar thermal pump)	---	---
F13	Errors	Elist – Errors list	---	---
		Ereset – Delete errors list	---	---
F14	Restore Values	Restore all the parameters to factory values	---	---

8. ERRORS

The installation, assembly and repair of the equipment can only be carried out by qualified technicians.

Symbol	Description	Problem / Checking
Er01 – S1	Probe 1 OFF.	<ul style="list-style-type: none"> • Lack of temperature probe. Check for probe. • Probe disconnected from controller – Check that the connector is well attached to the electronic plate and/or the connection terminals are secure.
Er02 – S2	Probe 2 OFF.	
Er03 – S3	Probe 3 OFF.	
Er04 – S4	Probe 4 OFF.	
Er11 – S1	Probe 1 short circuit	<ul style="list-style-type: none"> • Damaged probe – Measure internal resistance of probe which is approximately 10 KΩ at the temperature of 25 °C.
Er12 – S2	Probe 2 short circuit	
Er13 – S3	Probe 3 short circuit	
Er14 – S4	Probe 4 short circuit	
Er20 – TA	Anomaly detected in the water temperature	<ul style="list-style-type: none"> • Water temperature in storage water heater is too hot – Check that there is no anomaly in the electronic board, such as a damaged relay. • Temperature probes in short-circuit – Measure internal resistance of probe, it should be approximately 10 KΩ at the temperature of 25 °C, check that the connector is well attached to the electronic plate and the connection terminals are in good condition.
Er21 – DF	Anomaly detected in the defrost cycle (Too many defrost cycles in a short period of time).	<ul style="list-style-type: none"> • Measure internal resistance of probe, it should be approximately 10 KΩ at the temperature of 25 °C, check that the connector is well attached to the electronic plate and the connection terminals are in good condition. • Low external temperatures • Lack of refrigerant • Leak on the fluid circuit
Er22 – LT	Water low temperature alarm	<ul style="list-style-type: none"> • Water temperature in the boiler lower than 0 °C.
Er23 – LP	Protection system active	<ul style="list-style-type: none"> • Low Pressure switch – Verify if the switch is well connected in the command panel. • Low external temperatures • Lack of refrigerant – Incomplete refrigerant charge or leak..
Er24 – HP	Protection system active	<ul style="list-style-type: none"> • High pressure switch – Verify if the switch is well connected in the command panel. • Fluid circuit obstructed (expansion valve or filter).
Er25 – FS	Protection system active	<ul style="list-style-type: none"> • Lack of water / water circuit obstructed in the solar thermal installation;
LINK ERROR	Communication failure between display and power board	<ul style="list-style-type: none"> • Connection cable between display and command panel – Check the cable is in good condition or that the plugs are correctly inserted (display and command panel)
Pcp	Anomaly detected in the compressor	<ul style="list-style-type: none"> • Compressor is active but not working – check that the compressor fuse is blown and/or if the compressor connection terminals are well connected.
Phe	Anomaly detected in the electrical heater	<ul style="list-style-type: none"> • Electrical heater is active but not working – check the status of the electrical heater and/or if the connection terminals are well connected.

9. PROBE CHART

The probes installed in the equipment (S1, S2, S3 e S4) are NTC 10k Ω @25°C.

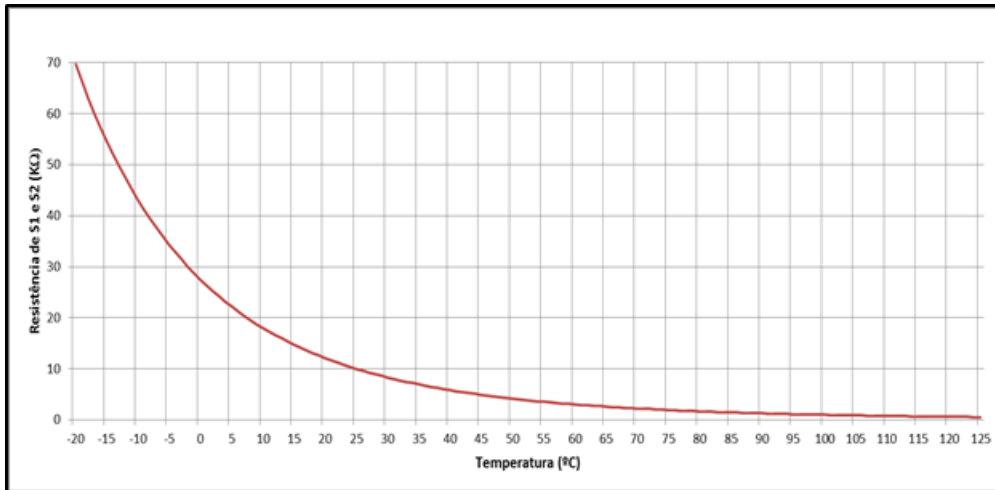



10. TROUBLESHOOTING

Problem	Possible Causes	How to Proceed
Failure in electronic board	Power supply failure	Check the power supply Check the corresponding circuit breaker
	Cable damaged or disconnected	Check the integrity of the electronic board's electric circuit
Low water temperature or lack of hot water	Low temperature programmed as the set-point	Adjust the temperature of the set-point. 53°C from factory
	Error activation	Check the presence of error on electronic board and consult the table of errors
	Cable damaged or disconnected	Check the connection of equipment to the plug Check that the corresponding circuit-breaker is connected Check the integrity of the cables Check that the electrical cable is disconnected from the power board Check electric protection (fuse)
	Vacation mode ON	Turn OFF the vacation mode
	Equipment or compressor OFF	Check "5.4 Start up of the system"
	Use of large amount of hot water	Change the equipment to "BOOST" mode for a fast water heating
	Return of hot water into the cold water circuit (safety device incorrectly installed or damaged)	Shut off the cold water supply valve to switch off the safety device. Open a hot water tap. Wait 10 minutes and if you get hot water, replace the faulty plumbing and/or proceed with the correct positioning of the safety device Clean the filter of the safety device
	ECO Mode selected and low external temperature	Change the equipment to "AUTO" mode to initiate automatic management of system Change the equipment to "BOOST" mode for a fast water heating
Electric heater OFF	Make sure the backup electric heater has power supply	
Water is too hot and/ or there is steam	Problem with the probe	Check error display on electronic board
	Problem with the safety thermostat	Check correct running of safety thermostat
Too much usage of the electric heater as a backup (auto mode)	Low external temperature	The running of the equipment depends on weather conditions
	Low water temperature	The running of the equipment depends on the inlet water temperature
	Low voltage installation	Make sure the installation is supplied with the indicated value for voltage
	Heat pump Error	Check the error display in the electronic board
	Evaporator blocked	Clean the evaporator
Fan blocked	Check the status of the fan (dust, wire...)	

Problem	Possible Causes	How to Proceed
Low hot water flow rate	Hydraulic circuit blocked	Check the condition of the hydraulic circuit
Water discharge on the safety group	Absence or incorrect sizing of expansion vessel (if leak is not continuous)	Installation and/or correct dimensioning of expansion vessel
	High mains pressure (if leak is continuous)	Check the reducing pressure valve (if installed) Install a reducing pressure valve (if not installed)
Power consumption is abnormally high and constant	Leak or obstruction in refrigerant circuit	Check that the piping is not damaged Use equipment suitable for checking leaks in the circuit
	Dire environmental conditions	
Electrical heater not working	Safety thermostat ON	Check the condition of the thermostat
	Defective electric heater	Check the electric heater
Bad odour	Absence of siphon or siphon without water	Install and make sure the siphon has water
Undraining condensation	Drainage circuit blocked	Clean the condensation circuit
	Drain pipe blocked	Check the draing pipe

11. SYSTEM MAINTENANCE

 WARNING	<p>Before undertaking any maintenance operation on the equipment, make sure it is not plugged to the power supply! Wait until the fan comes to a complete stop.</p>
-----------------------------------------------------------------------------------------------------	------------------------------------------------------------------------------------------------------------------------------------------------------------------------------------------

	<p>Although the fluid in the cooling circuit is environmentally-friendly, it must not be released into the atmosphere. Forms of recovery must be arranged.</p>
-----------------------------------------------------------------------------------	-------------------------------------------------------------------------------------------------------------------------------------------------------------------------------------

11.1. General Inspection

During the equipment's useful life, the owner should carry out a general inspection of the equipment, according to the place where the equipment is set up:

- External cleaning of equipment and surrounding areas with a wet cloth;
- Visual inspection of the whole equipment, with the purpose of detecting possible leaks and damaged devices.

11.2. Empty the Water Storage

 WARNING	<p>Remember that the water in the storage water tank is at a high temperature, so there is an associated risk of burns. Before emptying the storage water tank, allow the water temperature to drop to a level that avoids burns.</p>
------------------------------------------------------------------------------------------------------	------------------------------------------------------------------------------------------------------------------------------------------------------------------------------------------------------------------------------------------------------------

After ensuring the water temperature is at a safe level that will avoid burns, follow this procedure:

- Unplug the system from the power supply
- Shut off the water supply valve and open a hot water tap
- Open the system discharge valve

11.3. Filter of Reduction Valve

To periodically clean the filter of the reduction valve, you should:

- Shut off the water supply.
- Turn anti-clockwise until you remove tension from the spring
- Remove the handle
- Remove filter and clean

11.4. Condensate circuit

Make sure you check the condensate draining system and the drip tray in the maintenance and cleaning service routines of your system. Clean the drip tray used as it may contain accumulated dust from the outside, which may obstruct the condensates drainage holes. Make sure the holes and the condensate outlet pipe are not obstructed.

11.5. Cleaning Air Circuit

Make sure the air inlet filters are not obstructed, if applicable. Inspect at least once a year. The evaporator may have deposited dust. Clean it also, but be careful with its fins.



The evaporator's fins are quite thin, so there is additional risk of injuries. Take care not to damage them.

11.6. Safety Thermostat

The safety thermostat is disarmed every time that an anomaly occurs in the system so if you wish to rearm it you must find out the cause of this disarm. If you cannot figure out the cause of the disarm you must contact our after-sale assistance to solve your case. If everything is as it should be and you wish to rearm the thermostat you should proceed in the following manner:

- Remove the top unscrewing the 4 screws installed;
- Unscrew the lid (1);
- Press the button (2) to rearm the thermostat;
- Screw the lid back again (1) and place the lid again, screwing the 4 screws

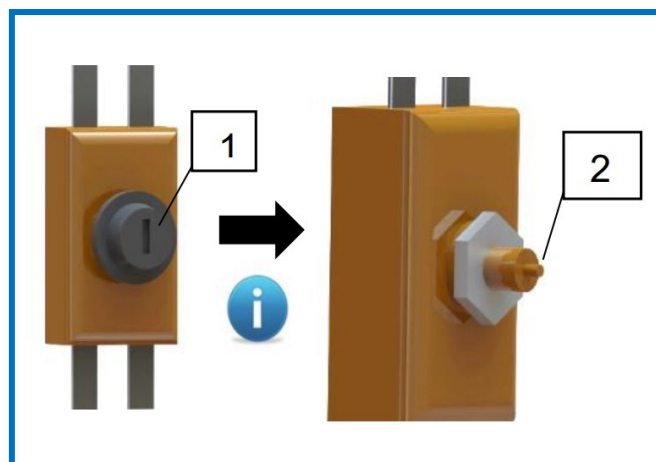
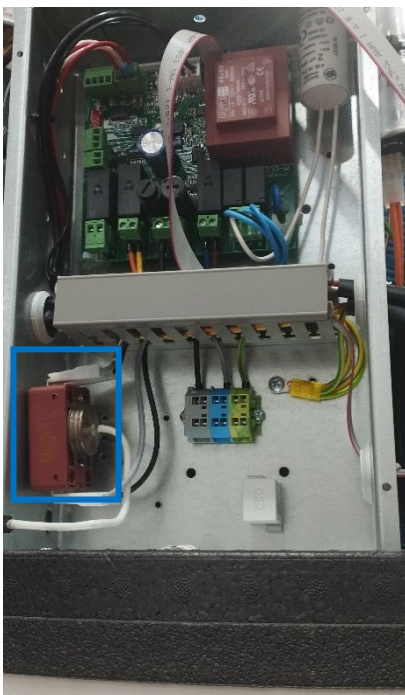

END

Warranty

This warranty covers all defects to the confirmed materials, excluding the payment of any type of personal damage indemnity caused directly or indirectly by the materials.

The periods indicated below start from the purchase date of the apparatus, 6 months at the latest from the leaving date from our storage warehouses.

Water Cylinder

(Domestic and Industrial)

5 Years: Stainless Steel (2+3 Years)*

5 Years Enamelled (2+3 Years)*

Manufacturer Warranty

Thermodynamic

Solar Panel

10 years against corrosion

Electrical components and moving parts:

- Thermodynamic Block
- Solar Block
- Solarbox
- Split
- Monobloc (except cylinder)
- Thermobox
- Inverter

2 Years

*The warranty extension of 3 years, against corrosion of the internal tank (Enamelled / Stainless Steel), is conditioned to the submission of:

- Warranty and Check Sheet at maximum 15 days after the installation.
- Documental evidence of the magnesium anode annual replacement (if applicable).
- Pictures of the installation where it's shown safety group, expansion vessel, hydraulic and electrical connections.

In case of warranty, the parts replaced are property of the manufacturer. A repair under the warranty is not reason for an extension of its term.

Warranty Exclusions

The warranty ceases to be effective when the apparatus is no longer connected, used or assembled in accordance with manufacturer instructions, or if there has been any form of intervention by unauthorized technicians, has the appearance of modifications and/or if the series number appears to have been removed or erased. The equipment should be installed by qualified technicians according to the rules in effects and/or the rules of the trade, or the instructions of our technical services. Further exclusions from warranty:

- Hot water tanks have been operating in water with the following indexes:
 - o Active chlorine > 0.2 ppm
 - o Chlorides > 50 mg/l (Inox)
 - o Hardness > 200 mg/l
 - o Conductibility > 600µS/cm (20°C)
 - o PH < 5,5 or PH > 9 (Sorensen at 20°C)
 - o Magnesium > 10 mg/l
 - o Calcium > 20 mg/l
 - o Sodium > 150 mg/l
 - o Iron > 1 mg/l
 - o If one of the water parameters has a higher value than stipulated by directive 236/98 (Portugal) or equivalent standard in the costumer's country
- Parts are subject to natural wear and tear – levers, switches, resistances, programmers, thermostats, etc.
- Breakdown due to incorrect handling, electrical discharges, flooding, humidity or by improper use of the apparatus.
- The warranty lapses if it is transferred to another owner, even if within the guarantee period.
- The warranty lapses if this certificate is incorrectly filled in, if it is violated or if it is returned after more than 15 days have passed since the installation or purchase date of the apparatus.

NOTE: This sheet must be properly filled, signed and stamped by the installer / reseller and returned to ENERGIE EST, Lda., otherwise the warranty will not be validated.

Send this installation sheet to warranty@energie.pt, writing the serial number of the equipment as subject.



ErP
READY

APPLIC TO
EUROPEAN
DIRECTIVE
FOR ENERGY
EFFICIENT
PRODUCTS



Informação mais detalhada em
energie.pt



Siga-nos em
ENERGIE PORTUGAL

Morada Zona Industrial de Laúndos, Lote 48
4570-311 Laúndos - Póvoa de Varzim PORTUGAL
Coordenadas GPS N 41 27.215' , W 8 43.669'
Telefone + 351 252 600 230

Fax + 351 252 600 239
E-mail energie@energie.pt
Web www.energie.pt

Projeto co-financiado por:



UNIÃO EUROPEIA
Fundos Europeus
Estruturais e de Investimento

O presente folheto foi criado apenas para informar e não constitui uma oferta contratual para a ENERGIE Est Lda. A ENERGIE Est Lda. compilou o conteúdo deste folheto de acordo com o melhor dos seus conhecimentos. Não é dada qualquer garantia expressa ou implícita no que toca à totalidade, precisão, fiabilidade ou adequação para um determinado fim do seu conteúdo e dos produtos e serviços que apresenta. As especificações estão sujeitas a alterações sem aviso prévio. A ENERGIE Est Lda. rejeita explicitamente quaisquer danos diretos ou indiretos, no seu sentido mais amplo, resultantes ou relacionados com a utilização e/ou interpretação deste folheto.