

BUFFER TANK

HEATING & COOLING



**BUFFER TANKS
HEATING &
COOLING,
ESPECIALLY
SUITABLE FOR
HEAT PUMPS**



BUFFER TANK HEATING & COOLING

AISI444 STAINLESS STEEL CYLINDER

ENERGIE buffer tanks are cylinders in which energy is temporarily stored, in the form of hot and/or cold water, for installations with heating and/or cooling by heat pumps, thus enabling the energy efficiency of the installation/building to be improved.

ENERGIE buffer tanks, produced of stainless steel with high-density insulation coating. Are available in 30, 50, 100, 200 and 500 litre capacities.

 PORTUGUESE MANUFACTURING



BUFFER TANK HEATING & COOLING

- AISI 444 stainless steel cylinder with external insulation in rigid injected polyurethane (free of CFC and HCFC), with a minimum thickness of 35 to 60mm.
- Vertical or horizontal installation.
- High density insulation.
- Low heat losses.
- Corrosion resistant.
- Simple installation.



See warranty conditions

Equipment: **Buffer Tank**

Model: **DI30-IN**

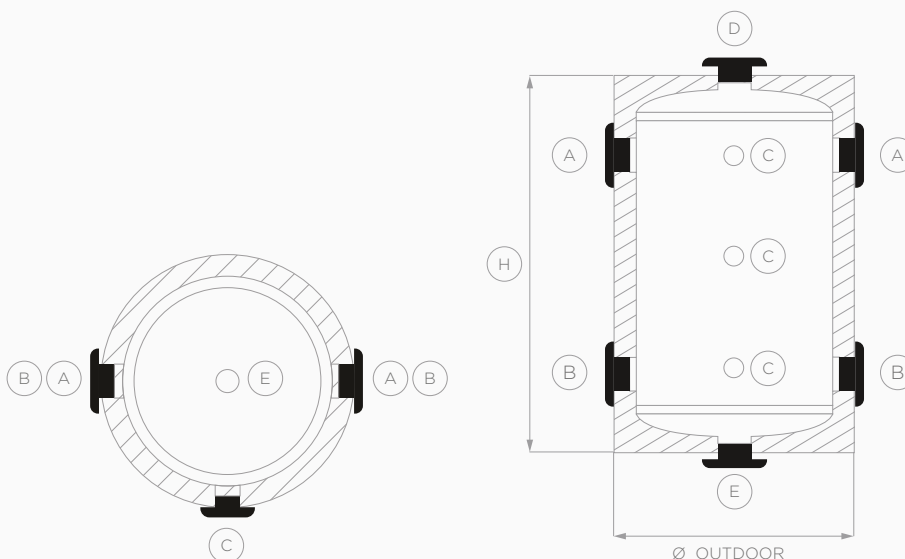

TECHNICAL DATA		DI30-IN	DI50-IN	DI100-IN	DI200-IN	DI500-IN
Nominal capacity	l	30	50	100	200	500
Application		Wall	Wall	Wall	Vertical	Vertical
Max. operating pressure	bar	6	6	6	6	6
Max. temperature	°C	90	90	90	90	90
Insulation	mm	60	60	60	60	60
Thermal conduction insulation	W/m.k	0,025	0,025	0,025	0,025	0,025
Insulation density	kg/m ³	45	45	45	45	45
Static losses	W	21	34	35	59	93
Energy Efficiency Class		A	A	B	B	C
Empty weight	Kg	10	27	33	52	89
H (height)	mm	595	650	1050	1300	1950
Ø (diameter)	mm	300	500	500	600	720
A, B (connections)		1"/F	1 1/4F	1 1/2F	1 1/2F	3"F
C (probes)		1/2"F	1/2"F	1/2"F	1/2"F	1/2"F
D (top connection)		1"F	1 1/4F	1 1/4F	1 1/4F	1 1/4F
E (outflow)		1"F	-	-	-	-

Equipment: **Buffer Tank**
 Model: **DI50-N / DI100-IN / DI200-IN / DI500-IN**

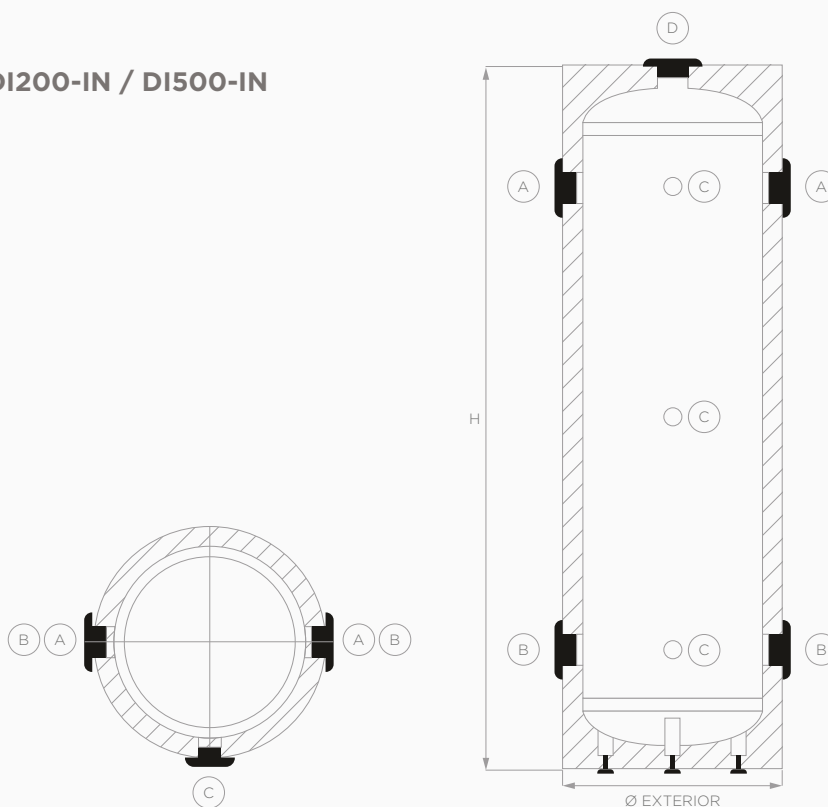

This flyer has been created for information purposes only and does not constitute a contractual offer for ENERGIE EST Lda.. The ENERGIE EST Lda. has compiled the contents of this flyer to the best of its knowledge. No express or implied guarantee is given regarding the completeness, accuracy, reliability or fitness for a particular purpose of its content and the products and services it presents. Specifications are subject to change without notice. ENERGIE EST Lda. explicitly rejects any direct or indirect damages, in its broadest sense, resulting from or related to the use and/or interpretation of this flyer. R2V0/2024



Project co-financed by:



Zona Industrial de Laúndos
Lote 48, 4570-311 Laúndos
Póvoa de Varzim, Portugal
EMAIL energie@energie.pt
SITE www.energie.pt

Follow us on:

ENERGIE PORTUGAL



Authorized dealer