

LARGE VOLUME ACCUMULATOR

DOMESTIC HOT
WATER



**LARGE VOLUME
ACCUMULATOR**
SOLUTIONS FOR
DOMESTIC HOT WATER,
SUITABLE FOR
OPERATION
WITH HEAT PUMPS



SIMPLICITY AND COMFORT

TERMO XL are available in the standard capacities of 750, 1000, 1500, 2000, 2500 and 3000 litres and they may be produced in line with the needs of the client, in the capacities of 4000, 5000 and 6000 litres.

For the whole TERMO XL range, there is the possibility of adaptation to various types of configurations, number and cooling coil exchange area, thickness of the polyurethane insulation, integration of end caps of different sizes.

ENERGIE is concerned with meeting the customer's needs, adapting the type of steel in the tank, the volume, dimensions, leverage, connection positions, to the design and architectural requirements.

Whether replacing gas, diesel or pellet boilers, as well as when combining the reduction of energy consumption and improvements in energy efficiency in conjunction with traditional solar thermal systems, this is the ideal, optimised solution.

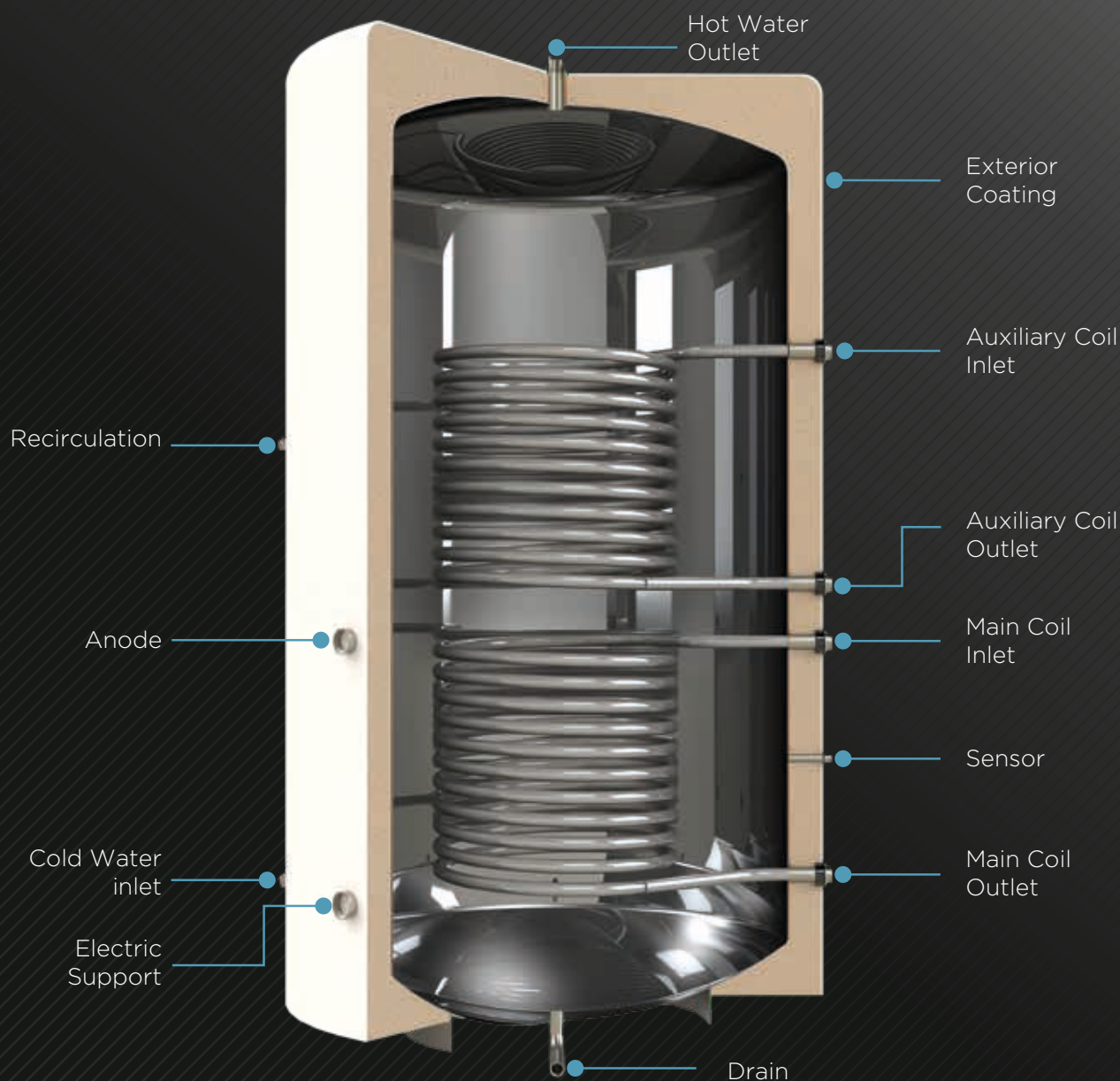

LARGE VOLUME ACCUMULATOR

DOMESTIC HOT WATER

ENERGIE presents its range of large capacity accumulators, TERMO XL, essential for comfort, energy efficiency and contribution to the preservation of the environment.

TERMO XL accumulators were designed to provide an extraordinary Hot Water storage capacity at the lowest cost, namely for dwellings, schools, small industries, public buildings, sports' bathing facilities and hotel facilities, inter alia.

These tanks are made of AISI316L stainless steel, available with capacities of 750, 1000, 1500, 2000, 2500 and 3000 litres.

 **PORTUGUESE MANUFACTURING**



LARGE VOLUME ACCUMULATOR FOR DWH

Main Features:

- Cylinder in AISI 316L
- Flexible Polyurethane Insulation with Variable Thickness (50mm or 100mm)
- DN200 & DN400 End Cap (Optional)
- Electric Support (Optional)
- Magnesium Anode
- Technical Fabric Coating



AISI 316L Stainless Steel Cylinder

Accumulators made from AISI316L stainless steel, highly resistant to corrosion.

50mm or 100mm Flexible Polyurethane Insulation

Thermal insulation in Flexible Polyurethane, 50 or 100 mm, which maintains the Domestic Hot Water storage temperature for long periods of time, without the need for any additional energy consumption.

DN200 & DN400 End Cap (optional)

All accumulators have the possibility of including an end cap, upon request, to be indicated when ordering.

Electric Support (optional)

All accumulators have the possibility of including an electrical support resistance with an external regulation thermostat, upon request, to be indicated when ordering.

Magnesium Anode

These accumulators have high anti-corrosion protection, through a magnesium protection anode, which guarantees great durability.

Technical Fabric Coating

The fabrics are manufactured from durable and resistant materials, designed to withstand operating conditions subject to the temperatures and humidity of a technical area (engine room).

It allows the accumulator to be aesthetically and functionally finished in accordance with the highest technical requirements, prolonging its working life and maintaining an attractive appearance over time.

COMPATIBILITY WITH AQUAPURA INVERTER ENERGY HEAT PUMPS

TERMO XL ENERGIE accumulators have now become more relevant due to their versatility in the application with the new AQUAPURA INVERTER heat pump range for DHW (Domestic Hot Water), Heating/Cooling solutions, or both solutions simultaneously, allowing you to improve and approach with confidence energy efficiency in any project. TERMO XL accumulators are compatible with ENERGIE heat pumps from 8 to 60 kW, medium and high temperature.

INSTALLATION SCENARIOS

DOMESTIC HOT WATER INSTALLATION

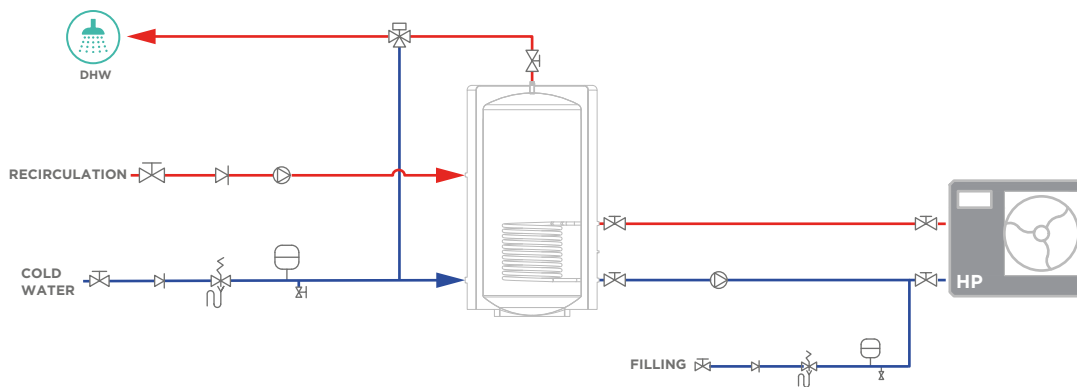

DOMESTIC HOT WATER INSTALLATION + BUFFER TANK

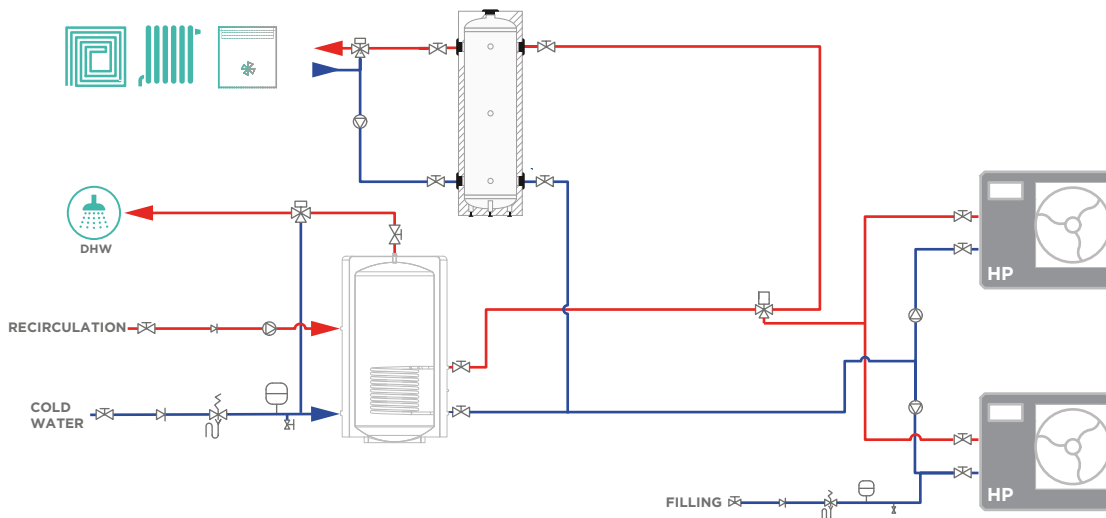

DOMESTIC HOT WATER INSTALLATION WITH THERMAL SUPPORT

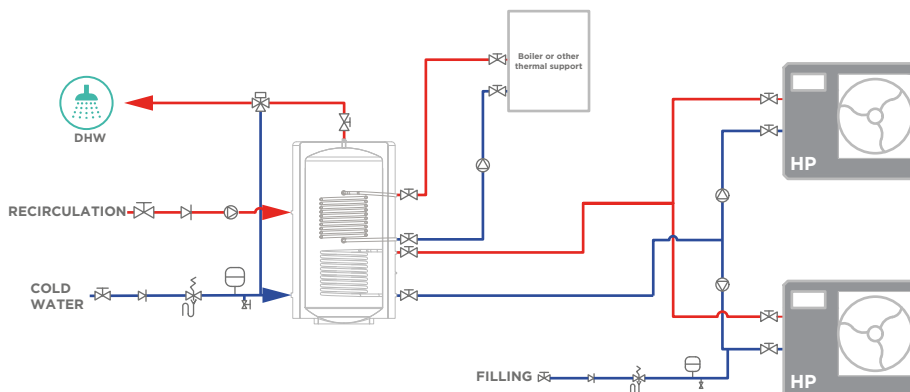

TERMO XL ACCUMULATOR TECHNICAL DATA			750I	1000I	1500I	2000I	2500I	3000I
Cylinder	Capacity	L	750	1000	1500	2000	2500	3000
	Max Working Pressure	Bar	8	8	8	8	8	8
	Max Running Temperature	°C	90	90	90	90	90	90
	Height*	mm	2000	2050	2100	2150	2200	2300
	Ø Exterior*	mm	800	930	1140	1300	1400	1500
TERMO XL ACCUMULATOR (1 COIL)			750IX	1000IX	1500IX	2000IX	2500IX	3000IX
Main Coil	Swap Area	m ²	2,83	3,62	4,21	5,058	5,90	6,74
	Volume	L	27,18	36,24	45,30	54,36	63,44	72,49
	Maximum Pressure	Bar	10	10	10	10	10	10
	Maximum Temperature	°C	120	120	120	120	120	120
	Max Power Exchange	kW	99	127	155	235	295	350
TERMO XL ACCUMULATOR XL (2 COILS)			750IXX	1000IXX	1500IXX	2000IXX	2500IXX	3000IXX
Auxiliary Coil	Swap Area	m ²	1,75	2,83	3,62	4,21	5,05	5,90
	Volume	L	18,12	27,18	36,24	45,30	54,67	63,44
	Maximum Pressure	Bar	10	10	10	10	10	10
	Maximum Temperature	°C	120	120	120	120	120	120
	Max Power Exchange	kW	62	99	127	155	235	295
TERMO XL ACCUMULATOR XL (1 COIL)			750IXL	1000IXL	1500IXL	2000IXL	2500IXL	3000IXL
XL Coil	Swap Area	m ²	5,93	6,34	7,18	8,01	8,84	9,67
	Volume	L	63,43	67,96	77,02	86,08	95,15	104,21
	Maximum Pressure	Bar	10	10	10	10	10	10
	Maximum Temperature	°C	120	120	120	120	120	120
	Max Power Exchange	kW	298	330	380	425	460	510

* Dimensions assuming a polyurethane insulation thickness of 50mm. If the tank has an insulation thickness of 100mm, the diameter and height of the tank increase by 100 and 50mm, respectively.

TERMO XL ACCUMULATOR DESIGNATION (mm) CONNECTIONS		750	1000	1500	2000	2500	3000
A	DHW Outlet	2000 1 1/4" F	2050 1 1/4" F	2100 1 1/2" F	2150 2" F	2200 2" F	2300 2" F
B	Auxiliary Coil Inlet	1640 1 1/4" F	1670 1 1/4" F	1685 1 1/4" F	1725 1 1/4" F	1755 1 1/4" F	1810 1 1/4" F
C	Auxiliary Coil Outlet	1040 1 1/4" F	1070 1 1/4" F	1085 1 1/4" F	1125 1 1/4" F	1155 1 1/4" F	1210 1 1/4" F
D	Main Coil Inlet	940 1 1/4" F	970 1 1/4" F	985 1 1/4" F	1025 1 1/4" F	1055 1 1/4" F	1110 1 1/4" F
E*	Sensor	640 1/2" F	670 1/2" F	685 1/2" F	725 1/2" F	755 1/2" F	810 1/2" F
F	Main Coil Outlet	340 1 1/4" F	370 1 1/4" F	385 1 1/4" F	425 1 1/4" F	455 1 1/4" F	510 1 1/4" F
G	Recirculation	1490 1 1/4" F	1520 1 1/4" F	1535 1 1/2" F	1575 2" F	1605 2" F	1660 2" F
H	Cold Water Inlet	340 1 1/4" F	370 1 1/4" F	385 1 1/2" F	425 2" F	455 2" F	510 2" F
I	Drain	- 1" F	- 1" F	- 1" F	- 1" F	- 1" F	- 1" F
J	Magnesium Anode	- 1 1/4" F	- 1 1/4" F	- 1 1/4" F	- 1 1/4" F	- 1 1/4" F	- 1 1/4" F
K	Electric Support	- 2" F	- 2" F	- 2" F	- 2" F	- 2" F	- 2" F
L	DN200 & DN400 End Cap (optional)	-	-	-	-	-	-

"The Dimensions and Connections of Tanks with XL Coil will be provided upon request"

Equipment: **TERMO XL Accumulator**

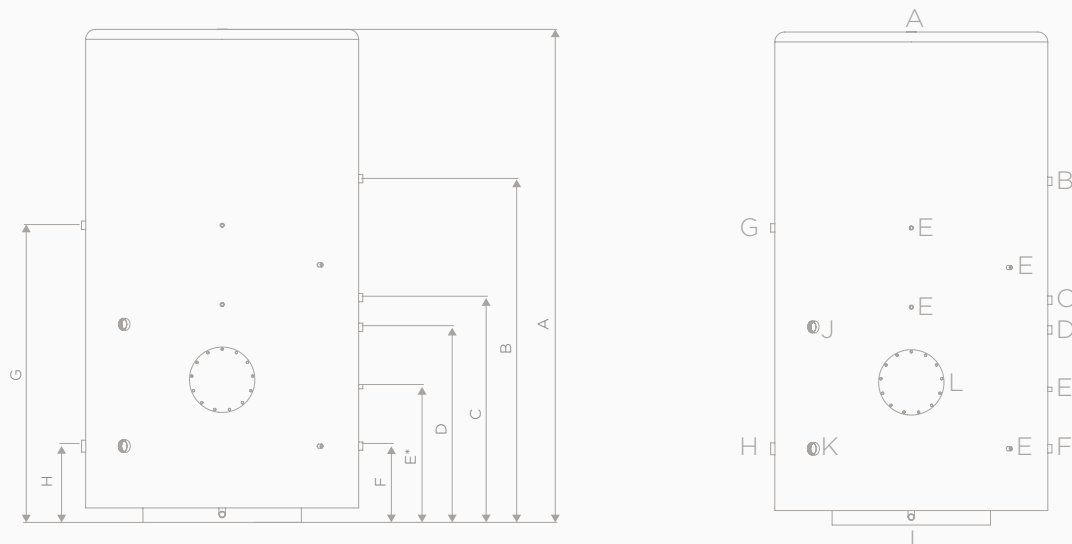

This flyer has been created for information purposes only and does not constitute a contractual offer for ENERGIE EST Lda.. The ENERGIE EST Lda. has compiled the contents of this flyer to the best of its knowledge. No express or implied guarantee is given regarding the completeness, accuracy, reliability or fitness for a particular purpose of its content and the products and services it presents. Specifications are subject to change without notice. ENERGIE EST Lda. explicitly rejects any direct or indirect damages, in its broadest sense, resulting from or related to the use and/or interpretation of this flyer.
ROVO/2024



Project co-financed by:



Zona Industrial de Laúndos
Lote 48, 4570-311 Laúndos
Póvoa de Varzim, Portugal
EMAIL energie@energie.pt
SITE www.energie.pt

Follow us on:



Authorized dealer