

NEW

AQUAPURA SPLIT GREEN

DOMESTIC
HOT WATER



DOMESTIC HOT WATER HEAT PUMP.
HIGH LEVEL OF EFFICIENCY FOR THE PRODUCTION OF DOMESTIC HOT WATER IN YOUR HOME!

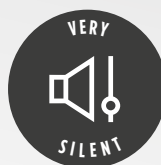

EFFICIENCY & QUALITY

OPERATING PRINCIPLE

The refrigerant fluid is pumped into an external heat exchanger (evaporator). Here, with the help of a fan, it absorbs energy from the surrounding air due to the temperature differential achieved outside, resulting in a phase change to the gaseous state.

It is then drawn into the mechanical part of the system, the compressor. At this stage, the fluid is compressed, pressure increases, and consequently its temperature rises. The fluid then flows to a second internal heat exchanger (condenser), where it transfers heat to the water stored in the tank.

As the temperature decreases, the fluid changes back to its liquid state. Its pressure is reduced by a throttling effect in the expansion valve, and the cycle starts again.

PORTUGUESE MANUFACTURING

- 1 Cylinder
- 2 Condenser
- 3 Electric heating element + Sensor
- 4 Magnesium Anode (if applicable)
- 5 Split Cover
- 6 Ventilator
- 7 Flare connection - easy installation (1/4" | 3/8")
- 8 Outdoor unit casing in polymer material (ABS)



See warranty conditions

NEW ELECTRONIC DISPLAY

MORE COMPLETE & INTUITIVE

The AQUAPURA SPLIT GREEN heat pump controller is a user-friendly and intuitive interface that allows:

- HYBRID | ECO | BOOST | SMART GRID | SOLAR modes
- Temperature setpoint adjustment for the heat pump
- Temperature setpoint adjustment for the backup heating element
- Integrated Wi-Fi for remote management
- Schedule programming and consumption statistics
- Parameter and temperature configuration





MAXIMUM
RETURN ON
INVESTMENT

HEAT PUMPS FOR DOMESTIC HOT WATER

We select the best components and subject our systems to the most rigorous quality tests to ensure maximum customer satisfaction.

Models 160L, 200L, and 300L can be recessed into a 60x60cm cabinet.



The AQUAPURA SPLIT GREEN heat pump is a modern, efficient, and ecofriendly solution for producing domestic hot water, ideal for both residential use and high-demand applications such as hotels, hospitals, or gyms.

With direct condensation technology, it consists of an outdoor unit and an internal storage tank, connected by piping up to 30 meters in total length, with a maximum height difference of 20 meters between units.

The AQUAPURA SPLIT GREEN heat pump operates at outdoor temperatures down to -15°C and allows the production of domestic hot water up to 65°C using only the compressor, enabling the direct replacement of conventional systems such as water heaters or electric cylinders.

- Wall-mounted and floor-standing heat pumps, with capacities from 160 to 500L
- Stainless steel tank (AISI 444 or Duplex 2205), with external condenser
- Domestic hot water production up to 65°C using only the compressor

- Rapid heating: DHW in less than 3 hours, up to 75% energy savings
- Quiet operation, no ducting required
- Flexible installation: up to 30 m distance and 20 m height difference
- Models can be recessed into a standard 60x60 cm cabinet

DISCOVER OUR APP ILETCOMFORT

AENERGIE presents the latest technological innovation integrated into its products: the iLetComfort app. With iLetComfort, customers can remotely manage their water heating equipment.

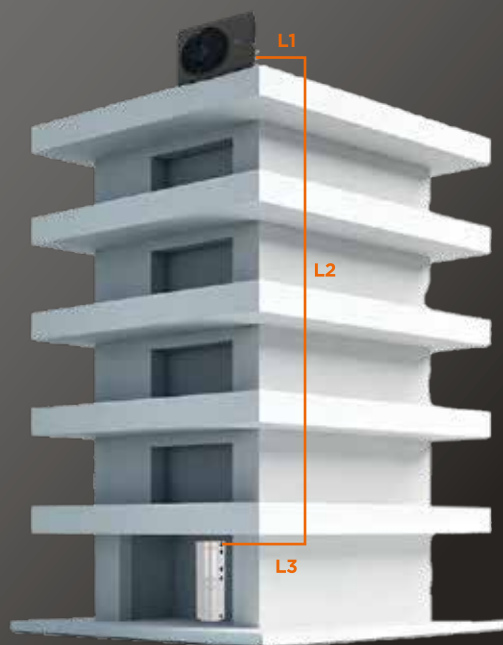

DISTANCE BETWEEN UNITS

The total piping length (**L1 + L2 + L3**) can be up to 30 meters. The maximum height difference between the outdoor unit and the water tank (**L2**) is 20 meters.

For lengths exceeding 10 meters, additional refrigerant must be added at a rate of 20 g/m for each meter above 10 m. For example, for an installation with 30 m of piping (liquid line length), the required additional refrigerant is:
 $20 \times (30 - 10) = 400 \text{ g}$.

CYLINDER

SPLIT 160i (MURAL)

Capacity	L	160
Dimensions (ø height)	mm	530/1141
Gross weight	Kg.	32
Material	-	Duplex 2205
Insulation	-	High density polyurethane (55mm)
Maximum water temperature	°C	80
Maximum operation pressure	bar	7
Thermal loss ¹	kWh/24h	0,94
Protection Index	-	IPX1
Auxiliary coil power	W	1500
Refrigerating connections	inch.	1/4" 3/8"

¹According to EN12897

OUTSIDE UNIT

Weight	Kg.	28
Refrigerating connections	inch.	1/4" 3/8"
Sound level	dB	53
Power supply	V/Hz	230 / 50
Protection Index	-	IPX1
Absorbed electrical power (HP) (med / max)	W	550/ 1100
Thermal power supplied (HP) (med / max)	W	1900/ 3520
Maximum distance between units	m	30 (altura max 20)
Outdoor operating temperature range	°C	-15 / 45
Refrigerating fluid	type/g	R454C / 900
Air flow	m ³ /h	1500

PERFORMANCE

Tapping profile	-	L
COP	-	3,36 ¹ 3,93 ² 4,28 ³
Amount of water removed at 40°C	L	191
Energy efficiency class	-	A+ ¹ A++ ² A++ ³
Energetic efficiency	%	139 ¹ 163 ² 178 ³
Annual electricity consumption	kWh/year	734 ¹ 629 ² 577 ³

¹ EN16147: Water heating from 10°C to 54°C (Air temperature 7°C)

² EN16147: Water heating from 10°C to 54°C (Air temperature 14°C)

³ EN16147: Water heating from 10°C to 54°C (Air temperature 20°C)

DIMENSIONS mm

OUTDOOR UNIT

A	767
B	555
C	452
D	302
E	327

DIMENSIONS mm

SPLIT 160 (MURAL)

A	1141
BØ	530
C	550
D	750
E	235
F	275
G	220

Equipment: **OUTDOOR UNIT SPLIT 160 | 200 | 300 | 500**

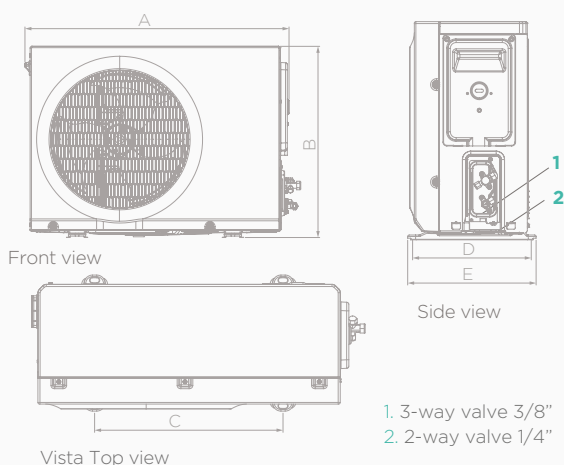

Equipment: **INDOOR UNIT SPLIT 160**

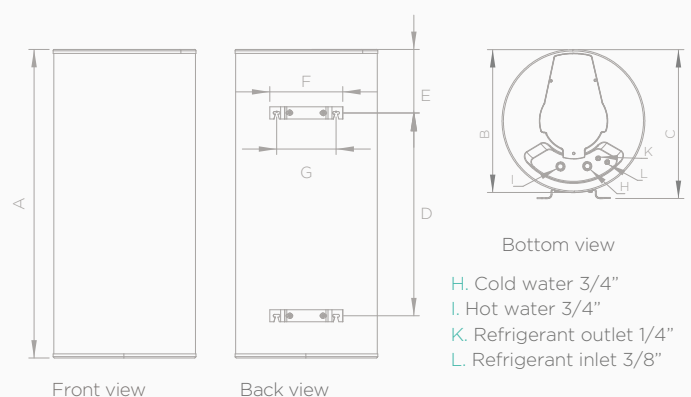

CYLINDER		SPLIT 200 I/IX	SPLIT 300 I/IX	SPLIT 500 I/IX
Capacity	L	200 / 190	270 / 260	455 / 445
Dimensions (ø height)	mm	580 / 1240	580 / 1540	650 / 2020
Gross weight	Kg.	46 / 51	50 / 57	73 / 95
Material	-	AISI 444 Duplex 2205		
Insulation	-	High density polyurethane (55mm)		
Corrosion protection	-	Magnesium anode 1" 1/4 (if applicable)		
Maximum water temperature	°C	80		
Maximum operation pressure	bar	7		
Thermal loss ¹	kWh/24h	0,99	1,01	1,81
Coil (ø length)	m	0,025 10	0,025 10	0,025 24
Coil thermal power ²	kW	20	20	54
Protection Index	-	IPX1		
Auxiliary coil power	W	1500	1500	2000
Refrigerating connections	inch.	1/4" 3/8"	1/4" 3/8"	1/4" 3/8"

¹ According to EN12897 | ² Primary circuit (Te=90°C; Ts=80°C); DHW circuit (Te=10°C; Ts=60°C)

OUTSIDE UNIT

Weight	Kg.	28		
Refrigerating connections	inch.	1/4" 3/8"		
Sound level	dB	53		
Power supply	V/Hz	230 / 50		
Protection Index	-	IPX1		
Absorbed electrical power (HP) (med / max)	W	550 / 1100		
Thermal power supplied (HP) (med / max)	W	1900 / 3520		
Maximum distance between units	m	30 (max. height 20)		
Outdoor operating temperature range	°C	-15 / 45		
Refrigerating fluid	type/g	R454C / 900		
Air flow	m ³ /h	1550		

PERFORMANCE

Tapping profile		L	XL	XXL
COP	-	3,38 ³ 4,05 ⁴ 4,30 ⁵	3,39 ³ 4,06 ⁴ 4,28 ⁵	3,25 ³ 3,83 ⁴ 4,12 ⁵
Amount of water removed at 40°C	L	281	351	599
Energy efficiency class	-	A+ ³ A++ ⁴ A++ ⁵	A+ ³ A++ ⁴ A++ ⁵	A+ ³ A+ ⁴ A++ ⁵
Energetic efficiency	%	140 ³ 169 ⁴ 180 ⁵	139 ³ 167 ⁴ 176 ⁵	134 ³ 158 ⁴ 171 ⁵
Annual electricity consumption	kWh/year	731 ³ 605 ⁴ 570 ⁵	1202 ³ 1003 ⁴ 951 ⁵	1604 ³ 1362 ⁴ 1263 ⁵

³ EN16147: Water heating from 10°C to 54°C (Air temperature 7°C) | ⁴ EN16147: Water heating from 10°C to 54°C (Air temperature 14°C) |

⁵ EN16147: Water heating from 10°C to 54°C (Air temperature 20°C)

DIMENSIONS mm	SPLIT 200 I/IX	SPLIT 300 I/IX	SPLIT 500 I/IX
A	131	131	102
B	231	231	237
C	435	435	657
D	690	690	784
E	-	840	1095
F	905	1205	1772
G	1030	1325	1937
H	1240	1540	2020
I	Ø 580	Ø 580	Ø 650
J	600	600	764
K	220	220	-

Equipment: **INDOOR UNIT SPLIT 200 | 300 | 500**

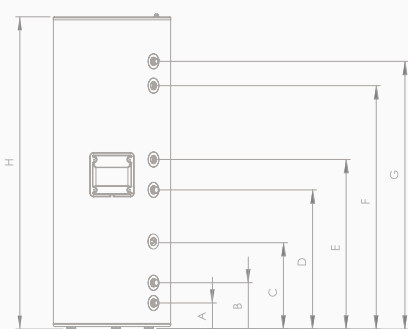

Equipment: **SPLIT 200 | 300**

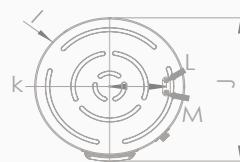

Vista de cima

- A. Cold water 3/4" (M)
- B. Coil outlet 1" (M)
- C. Instrumentation
- D. Coil inlet 1" (M)
- E. Recirculation 1/2" (F)
- F. PT Valve 1/2" (F)
- G. Hot water 3/4" (M)
- L. Refrigerant inlet 3/8"
- M. Refrigerant outlet 1/4"

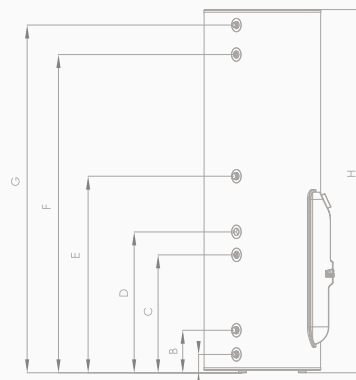

Equipment: **SPLIT 500**

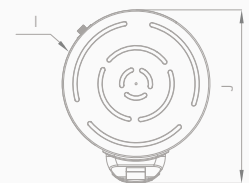

Top view

- A. Cold water 1"(M)
- B. Coil outlet 1"(M)
- C. Coil inlet 1"(M)
- D. Recirculation 3/4" (M)
- E. Magnesium Anode 1 1/4 (F)
- F. PT Valve 1/2" (F)
- G. Hot water 1"(M)

This flyer has been created for information purposes only and does not constitute a contractual offer for ENERGIE EST Lda. ENERGIE EST Lda. has compiled the contents of this flyer to the best of its knowledge. No express or implied guarantee is given regarding the completeness, accuracy, reliability or fitness for a particular purpose of its content and the products and services it presents. Specifications are subject to change without notice. ENERGIE EST Lda. explicitly rejects any direct or indirect damages, in its broadest sense, resulting from or related to the use and/or interpretation of this flyer. ROVI/2026



Zona Industrial de Laúndos
Lote 48, 4570-311 Laúndos
Póvoa de Varzim, Portugal
EMAIL energie@energie.pt
SITE www.energie.pt

Follow us on:

ENERGIE PORTUGAL



Authorized dealer